

# INDEX

## SEWER DETAILS

|        |   |
|--------|---|
| S-1    | STANDARD MANHOLE DETAIL   |
| S-2    | SANITARY SEWER COVER AND GENERAL NOTES                                      |
| S-3    | SHALLOW MANHOLE   |
| S-4    | OUTSIDE DROP MANHOLE (STANDARD NEW CONSTRUCTION)                            |
| S-5    | OUTSIDE DROP MANHOLE (STANDARD)   |
| S-6    | OUTSIDE DROP MANHOLE DETAIL   |
| S-7*   | INSIDE DROP MANHOLE DETAIL FOR RETROFIT<br>AND SPECIAL CONDITIONS ONLY      |
| S-8    | RUBBER BOOT AND PRECAST JOINT CONNECTION DETAIL                             |
| S-9    | SEWER LINE UTILITY CROSSING DETAIL  |
| S-10   | SEWER LATERAL DETAIL (SINGLE 4" RESIDENTIAL)(SINGLE 6" COMMERCIAL)          |
| S-11*  | SEWER LATERAL DETAIL (DOUBLE 6" RESIDENTIAL)                                |
| S-12   | CLEANOUT DETAIL   |
| S-13   | LOCATOR TAPE INSTALLATION FOR SEWER, WATER AND<br>RECLAIMED WATER PIPELINES |
| S-14   | SEWER CONDUIT CROSSING  |
| S-15   | TYPICAL LIFT STATION SITE PLAN  |
| S-16   | LIFT STATION POTABLE WATER SERVICE  |
| S-17*  | LIFT STATION WET WELL SECTION (SUBMERSIBLE)                                 |
| S-18   | LIFT STATION PLAN VIEW (SUBMERSIBLE)  |
| S-19*  | LIFT STATION CONSTRUCTION DESIGN NOTES (SUBMERSIBLE)                        |
| S-20*  | LIFT STATION EMERGENCY PUMP CONNECTION                                      |
| S-20A* | [*REMOVED]  |
| S-21*  | AIR RELEASE VALVE ON SANITARY FORCE MAIN                                    |
| S-22*  | PACKAGED LIFT STATION ELECTRICAL EQUIPMENT RACK                             |
| S-22A  | PACKAGED LIFT STATION ELECTRICAL PANEL SCHEMATIC                            |
| S-22B* | PACKAGED LIFT STATION ELECTRICAL PANEL SCHEMATIC                            |
| S-22C  | UNITARY SEWAGE PUMP STATION DETAIL  |
| S-22D  | PACKAGED LIFT STATION ELECTRICAL NOTES                                      |
| S-23*  | SANITARY SEWER DESIGN AND CONSTRUCTION NOTES                                |
| S-24   | SANITARY SEWER DESIGN AND CONSTRUCTION NOTES                                |
| S-25*  | SANITARY SEWER DESIGN AND CONSTRUCTION NOTES                                |
| S-26   | SANITARY SEWER DESIGN AND CONSTRUCTION NOTES                                |
| S-27   | SANITARY SEWER FORCE MAIN VALVE AND VALVE BOX                               |
| S-28   | TYPE "A" BEDDING AND TRENCH DETAIL  |
| S-29   | TYPE "B" BEDDING AND TRENCH DETAIL  |
| S-30   | SANITARY SEWER DOUBLE MANHOLE COVER   |
| S-31*  | EMERGENCY BACKUP PUMP OR GENERATOR  |



\*2024-07-20

STANDARD CONSTRUCTION DETAIL  
INDEX  
SEWER DETAILS

FILE NAME:

SEWINDX.DWG

DETAIL REF:

INDEX

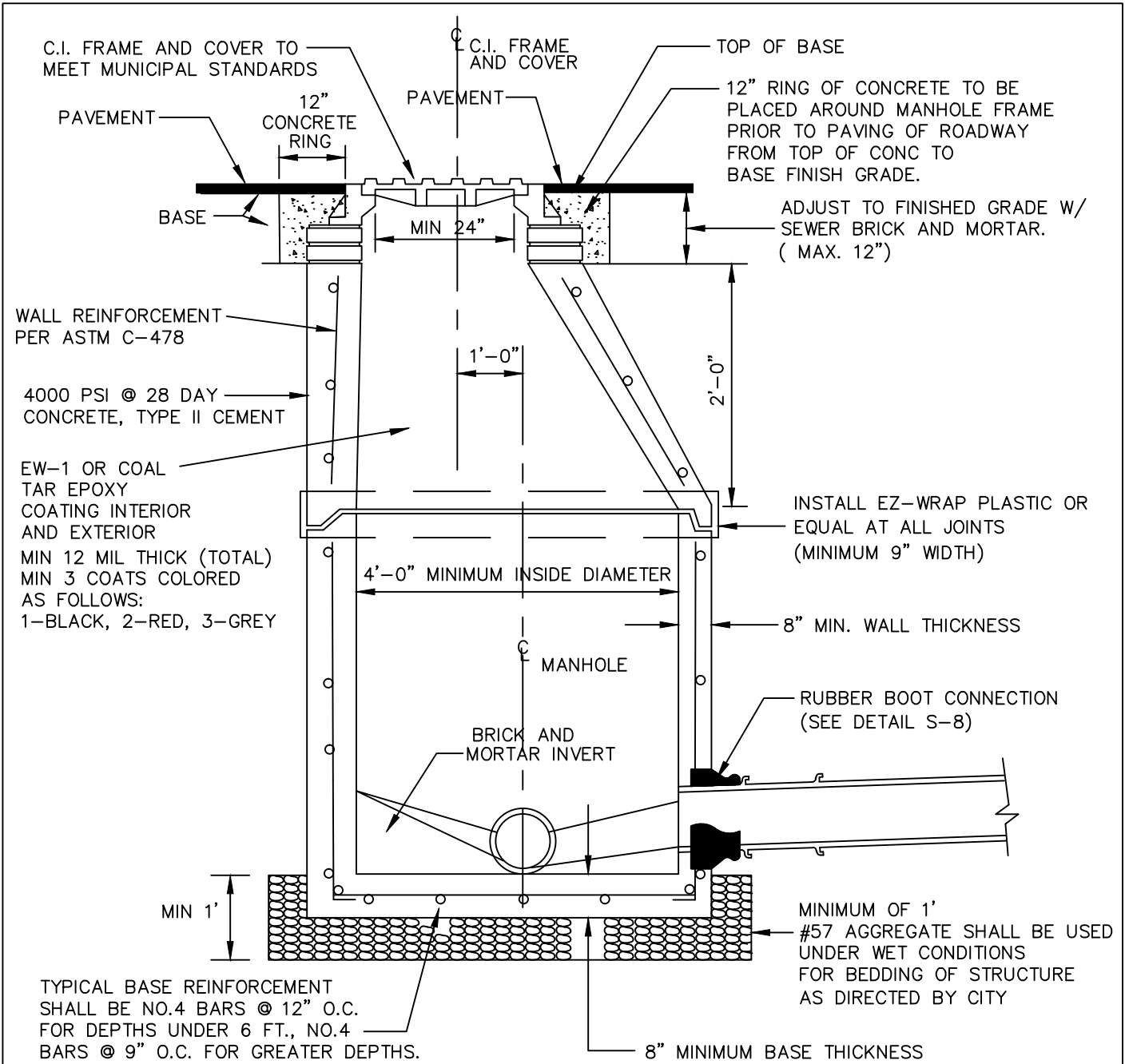

**NOTES:**

1. ON TRANSITIONS BETWEEN LARGER DIAMETER AND SMALLER SEWER COLLECTORS, OUTVERTS OF SEWERS SHALL BE MATCHED.
2. NON-PENETRATING PICK-HOLES IN ALL CONCRETE SECTIONS.
3. USE FARBERTITE BITUMASTIC SEALER BETWEEN SECTIONS OF MANHOLES.
4. 0.1' - DROP ACROSS MANHOLE TYP.
5. ALL MANHOLE TROUGHS AND BENCHES ARE TO BE EPOXY PAINTED BEFORE FINAL INSPECTION.
6. LAST MANHOLE UPSTREAM OF A LIFT STATION MUST BE LINED W/ SPECTRA SHIELD OR EQUAL.



2023-01-25

STANDARD CONSTRUCTION DETAIL  
STANDARD MANHOLE DETAIL

FILE NAME:

EW\_S1.DWG

DETAIL REF:

S-1

USF No. 117-BL-ORS  
 FRAME WT = 85 LBS.  
 COVER WT = 125 LBS.

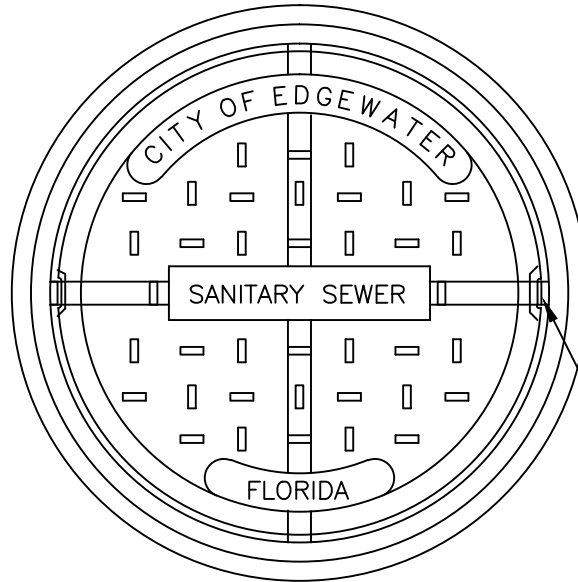

2 NON-PENETRATING  
 PICKHOLES

NOTES:

1. CEMENT USED IN PRECAST CONCRETE MIX SHALL BE TYPE II, ACID RESISTANT AND SULFIDE RESISTANT CONCRETE.
2. MORTAR TO CONTAIN "HYDRATITE", OR APPROVED EQUAL, TO PREVENT SHRINKAGE.
3. SUB-GRADE BENEATH MANHOLES SHALL BE UNDISTURBED GRANULAR UNSATURATED SOIL. No. 57 AGGREGATE STONE SHALL BE USED IN WET CONDITIONS AND/OR WHERE UNSUITABLE MATERIAL IS ENCOUNTERED.
4. ALL SEWER LINES SHALL BE VIDEOTAPED WITH "PAN AND TILT" CAMERA AND COPIES OF VIDEOS SUPPLIED TO THE ENVIRONMENTAL SERVICES DEPT. THE CITY MAY REQUIRE ADDITIONAL VIDEO TAPING, VIDEO TAPING OF LATERALS, AND/OR INFILTRATION/EXFILTRATION TESTS IF DEFECTS ARE APPARENT OR WORKMANSHIP IS QUESTIONABLE.
5. UNLESS DETAILED PLANS SHOW OTHERWISE, ALL MANHOLE RING AND COVER CASTINGS IN PAVED AREAS ARE TO BE ADJUSTED TO FINAL GRADE, SEALED AND SECURED IN PLACE WITH A CONCRETE COLLAR AFTER THE ROAD BASE IS PLACED AND JUST PRIOR TO PLACEMENT OF ASHPALT WEARING SURFACE.
6. CONTRACTOR SHALL PROVIDE THICKER MANHOLE WALLS AND BASES AS REQUIRED TO PREVENT FLOTATION BASED ON HISTORIC HIGH GROUND WATER TABLE ELEVATIONS AS DETERMINED USING ACCEPTED ENGINEERING PRACTICES AND/OR APPROVED BY ENVIRONMENTAL SERVICES DEPT.
7. CONCRETE COLLAR AROUND MANHOLE FRAME IS REQUIRED IN PAVED AREAS ONLY.
8. SHOP DRAWINGS FOR ALL STRUCTURES SHALL BE SUBMITTED TO AND APPROVED BY THE DESIGN ENGINEER PRIOR TO INSTALLATION WITH TWO COPIES FORWARDED BY THE DESIGN ENGINEER TO THE CITY.
9. TWO (2) COATS OF BITUMASTIC COATING INSIDE: 16 MIL
10. ONE (1) COAT OF BITUMASTIC COATING OUTSIDE: 8 MIL
11. FRAME AND COVER TO BE USF #117-BL-ORS .
12. NO BUG HOLES OR HONEYCOMB WILL BE ACCEPTED.
13. ENDS OF SECTION SHALL FIT FLUSH TOGETHER
14. SEDIMENTATION BOWLS REQUIRED FOR ALL NEW MANHOLES AND REHABILITATION STRUCTURES. RAINGUARD OR APPROVED EQUAL.



2023-01-25

STANDARD CONSTRUCTION DETAIL  
 SANITARY SEWER COVER & GENERAL NOTES

FILE NAME:

EW\_S2.DWG

DETAIL REF:

S-2

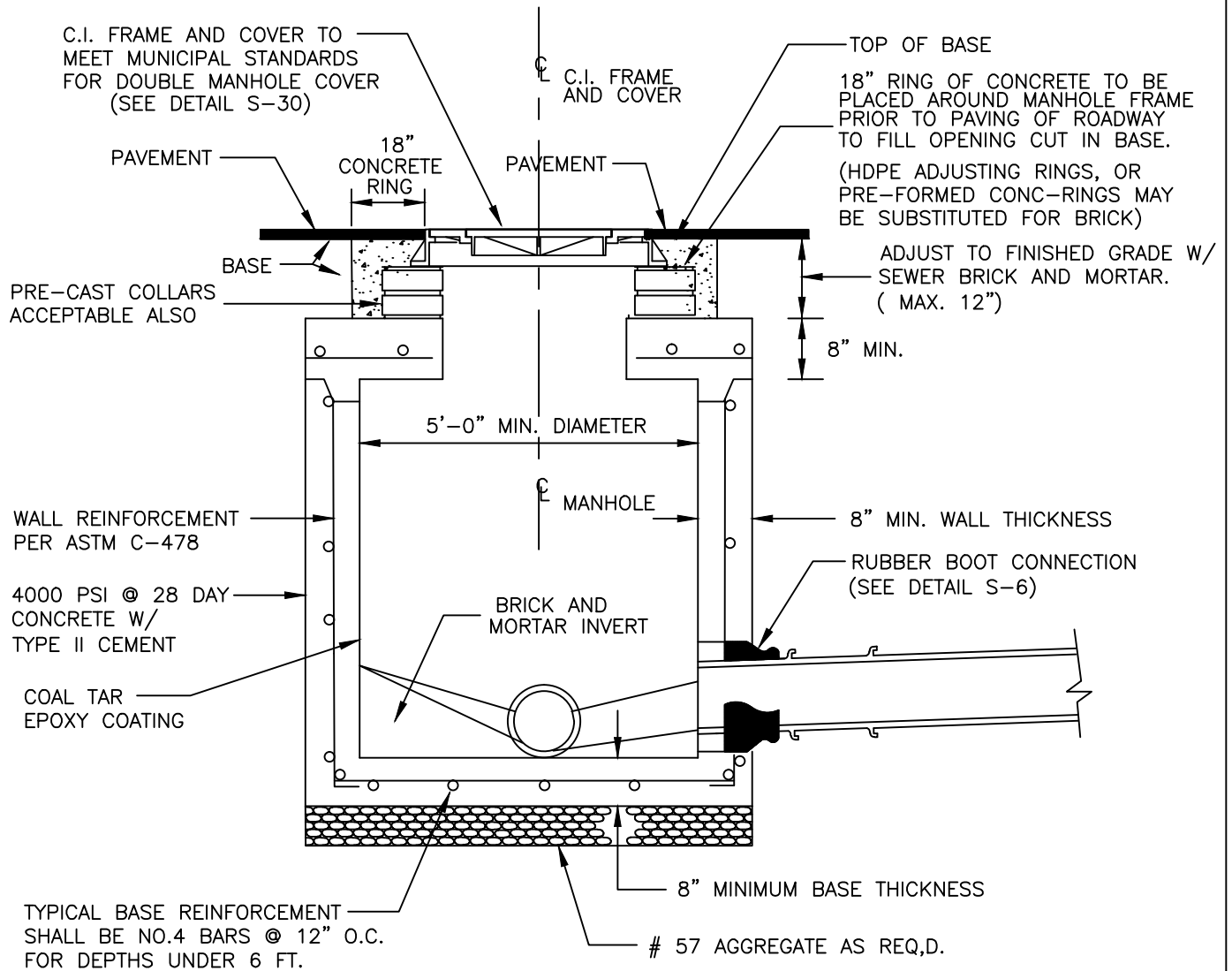

SECTION - SHALLOW MANHOLE

USE FOR MANHOLES OF 5'-0" OR LESS IN DEPTH

NOTES:

1. INSTALL EZ-WRAP PLASTIC OR EQUAL AT ALL JOINTS (MINIMUM 9" WIDTH).
2. NON-PENETRATING PICK-HOLES IN ALL CONCRETE SECTIONS.
3. USE FARBERTITE BITUMASTIC SEALER BETWEEN SECTIONS OF MANHOLE.



2023-01-25

STANDARD CONSTRUCTION DETAIL  
SHALLOW MANHOLE

FILE NAME:

EW\_S3.DWG

DETAIL REF:

S-3

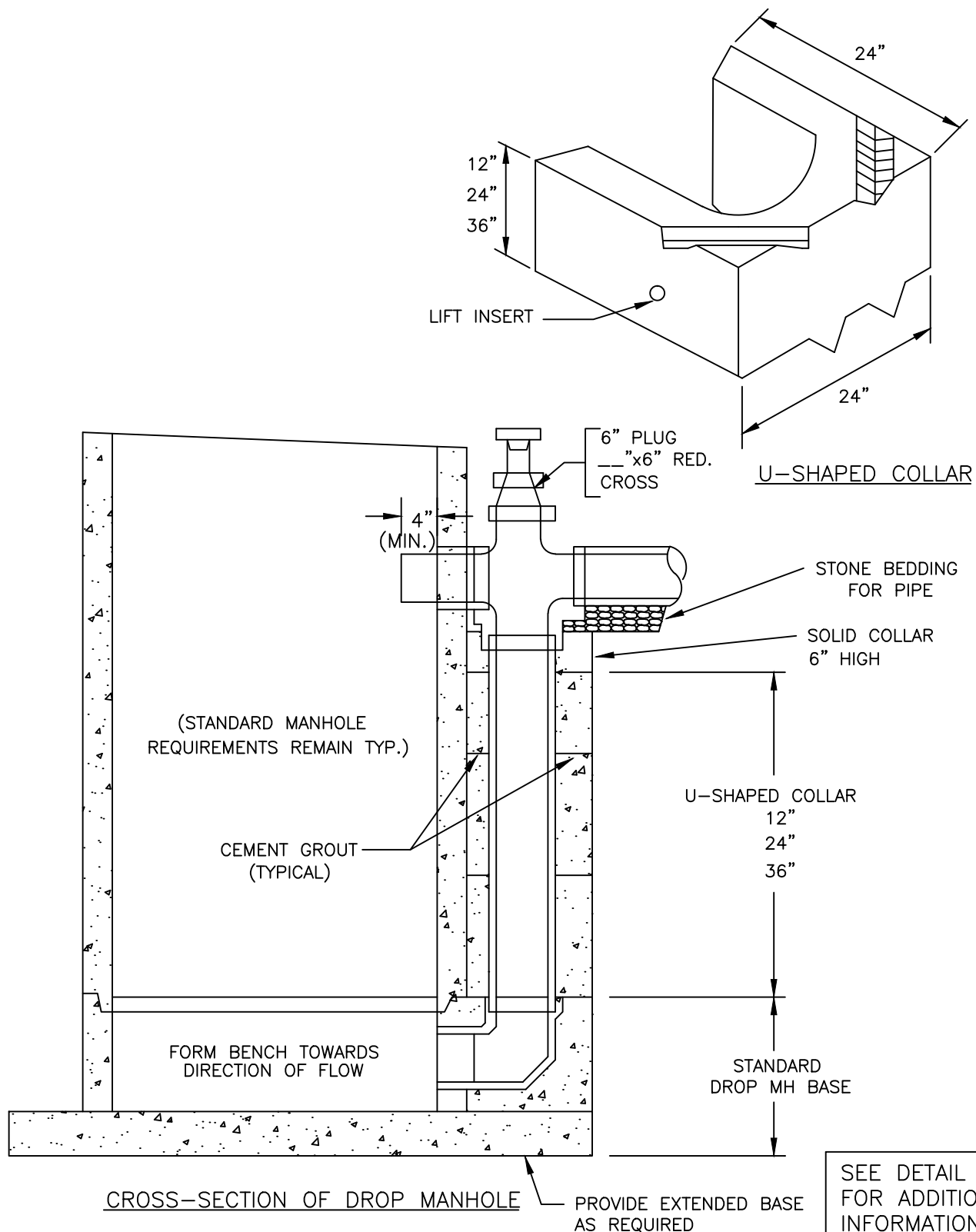

2023-01-25

STANDARD CONSTRUCTION DETAIL  
OUTSIDE DROP MANHOLE  
(STANDARD NEW CONSTRUCTION)

FILE NAME:

EW\_S4.DWG

DETAIL REF:

S-4

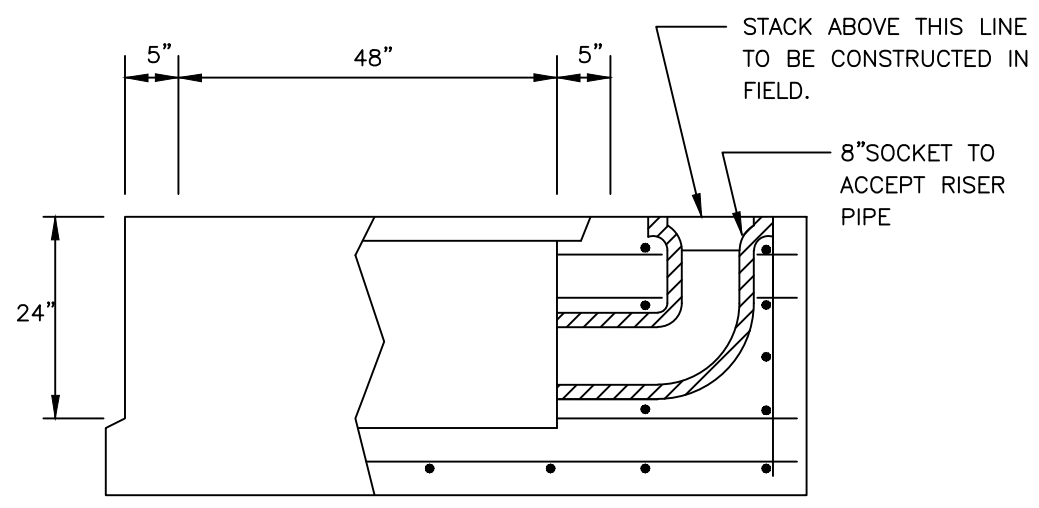
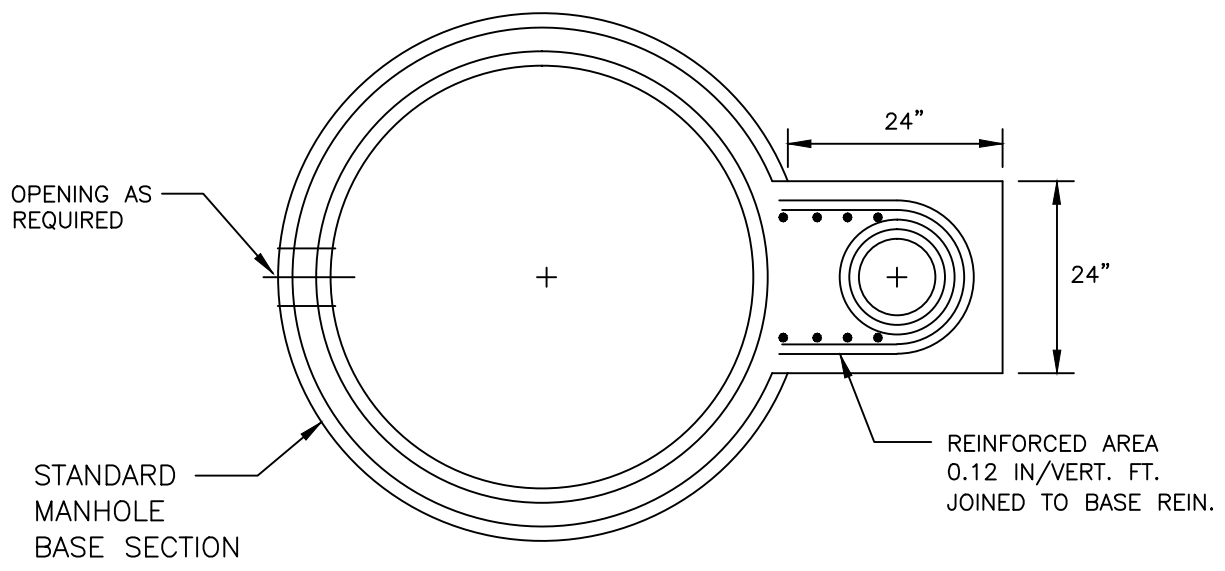

MANHOLE BASE WITH PRECAST DROP

MANHOLE DESIGN  
 MANHOLE DESIGN SPECIFICATIONS  
 CONFORM TO "PRECAST REINFORCED  
 CONCRETE MANHOLE SECTIONS.



2023-01-25

STANDARD CONSTRUCTION DETAIL  
 OUTSIDE DROP MANHOLE (STANDARD)

FILE NAME:  
 EW\_S5.DWG

DETAIL REF:  
 S-5

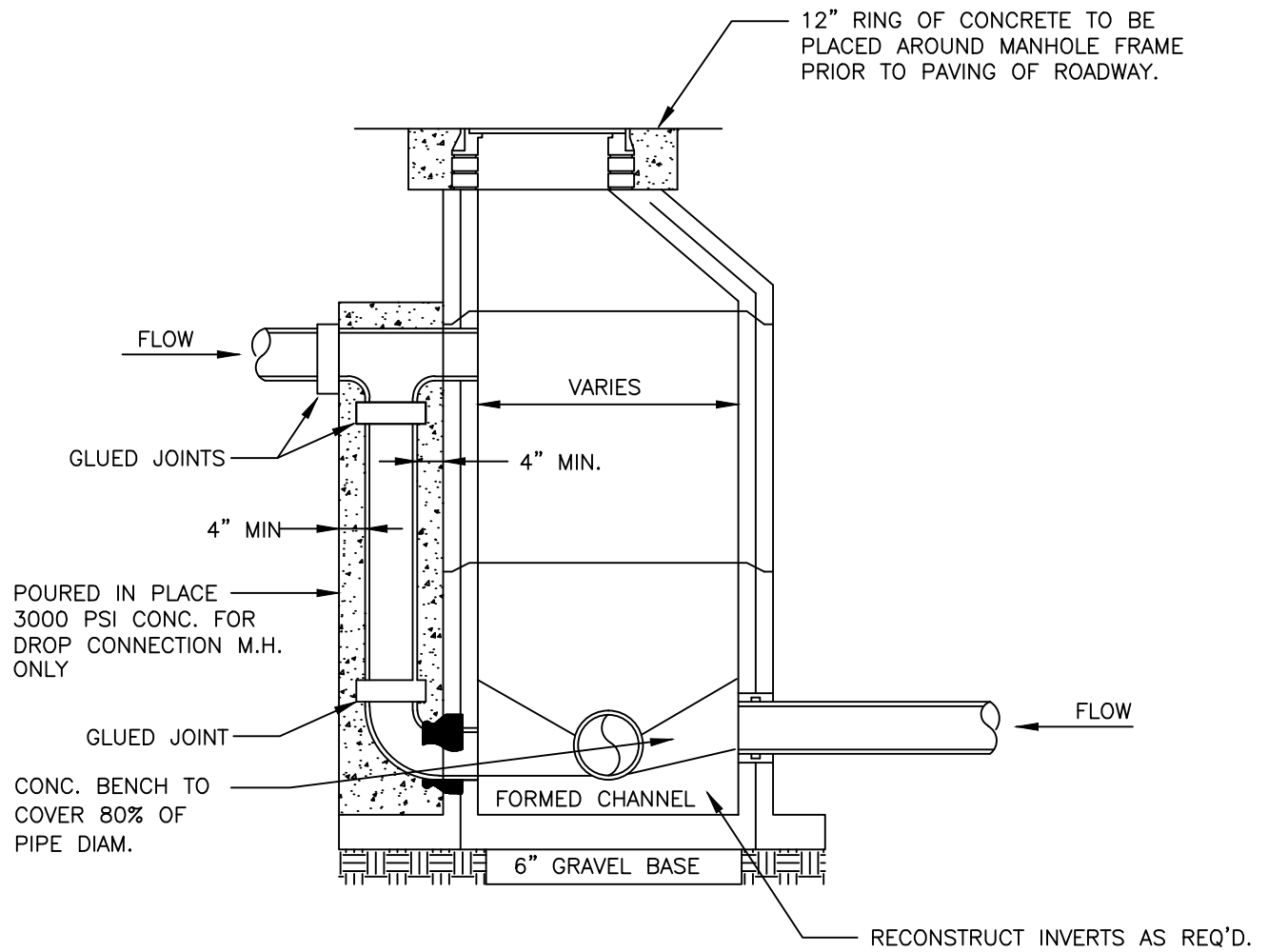

FOR SPECIAL CONDITIONS ONLY  
( I.E. RETROFIT CONSTRUCTION )

SEE DETAIL S-1  
FOR ADDITIONAL  
INFORMATION



2023-01-25

STANDARD CONSTRUCTION DETAIL  
OUTSIDE DROP MANHOLE DETAIL

FILE NAME:

EW\_S6.DWG

DETAIL REF:

S-6

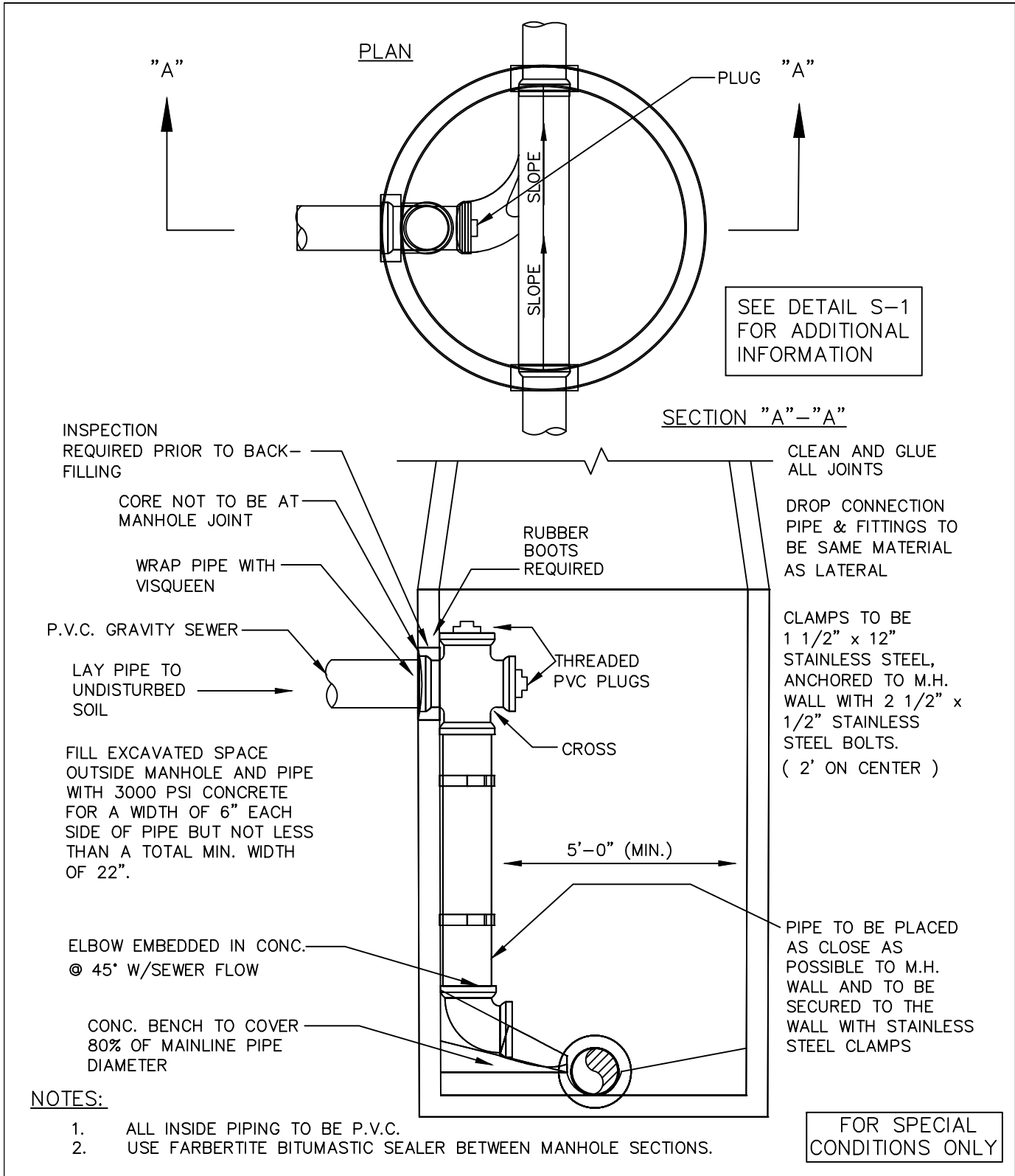

2024-07-20

STANDARD CONSTRUCTION DETAIL  
INSIDE DROP MANHOLE DETAIL FOR  
RETROFIT AND SPECIAL CONDITIONS ONLY

FILE NAME:

EW\_S7.DWG

DETAIL REF:

S-7



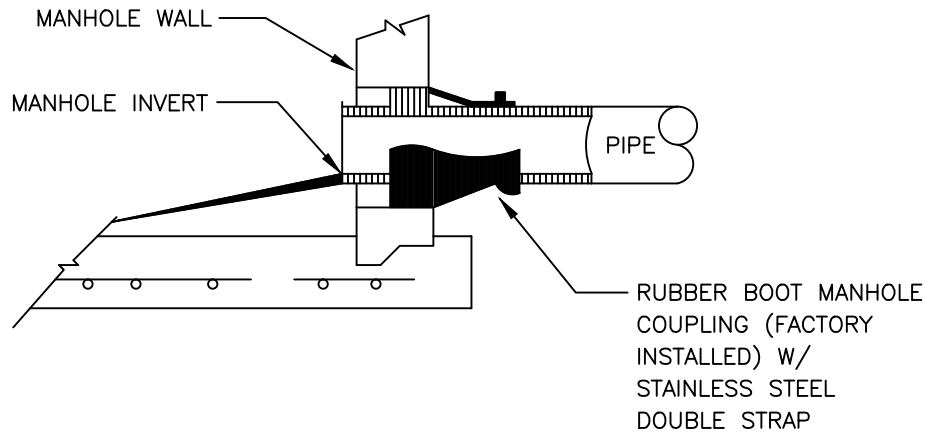

MANHOLE PIPE CONNECTION DETAIL  
FOR NEW CONNECTIONS IN EXISTING MANHOLES

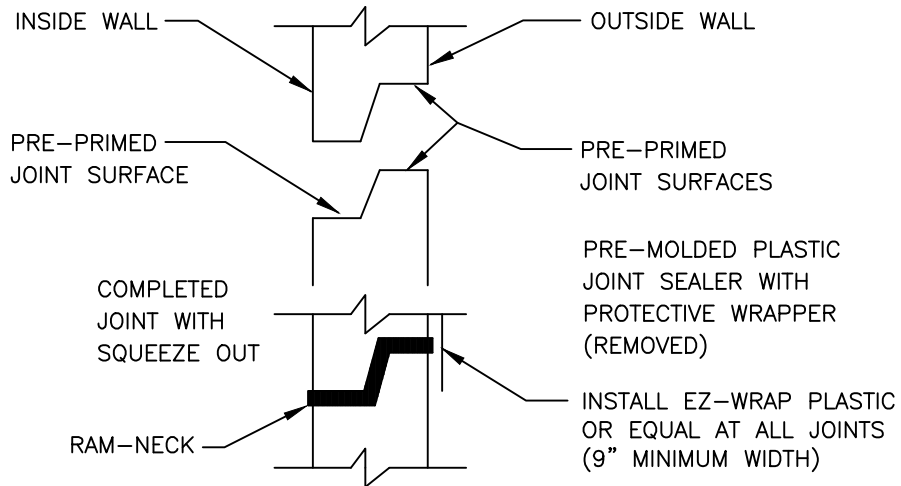

PRECAST JOINT CONNECTION

NOTES:

1. ALL NEW CONNECTIONS TO EXISTING SANITARY SEWER MANHOLES SHALL UTILIZE A CORING METHOD AND THE IN-FIELD INSTALLATION OF A RUBBER BOOT INTO THE MANHOLE.



2023-01-25

STANDARD CONSTRUCTION DETAIL  
 RUBBER BOOT AND PRECAST JOINT  
 CONNECTION DETAIL

FILE NAME:

EW\_S8.DWG

DETAIL REF:

S-8

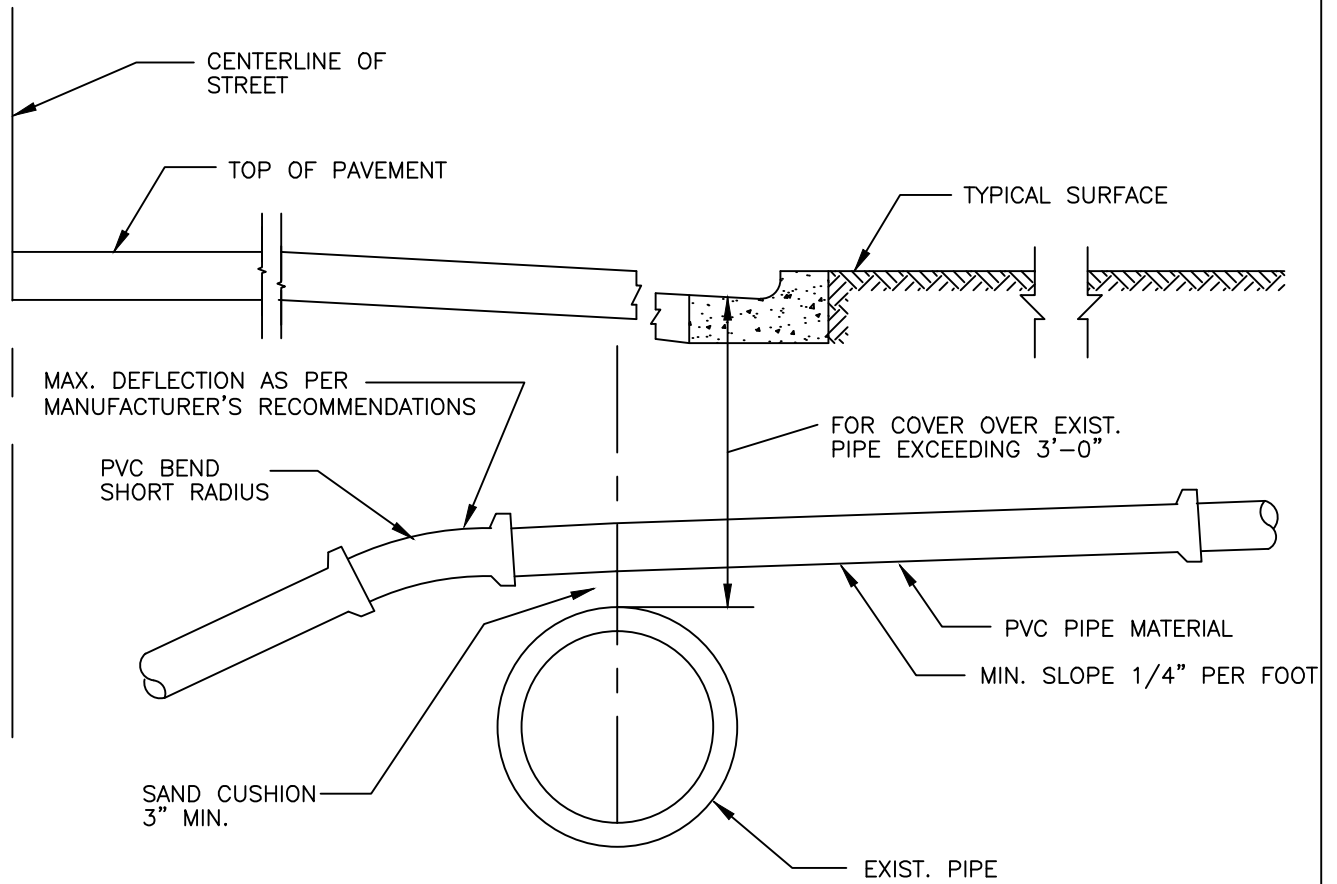

ALTERNATE GRADIENT FOR HOUSE SERVICE  
SEWERS AT CONFLICTS WITH EXISTING STORM  
SEWERS & OTHER EXISTING CONDUITS

APPROVED PIPE MATERIALS—PVC (SDR 26)



2023-01-25

STANDARD CONSTRUCTION DETAIL  
SEWER LINE UTILITY CROSSING DETAIL

FILE NAME:

EW\_S9.DWG

DETAIL REF:

S-9

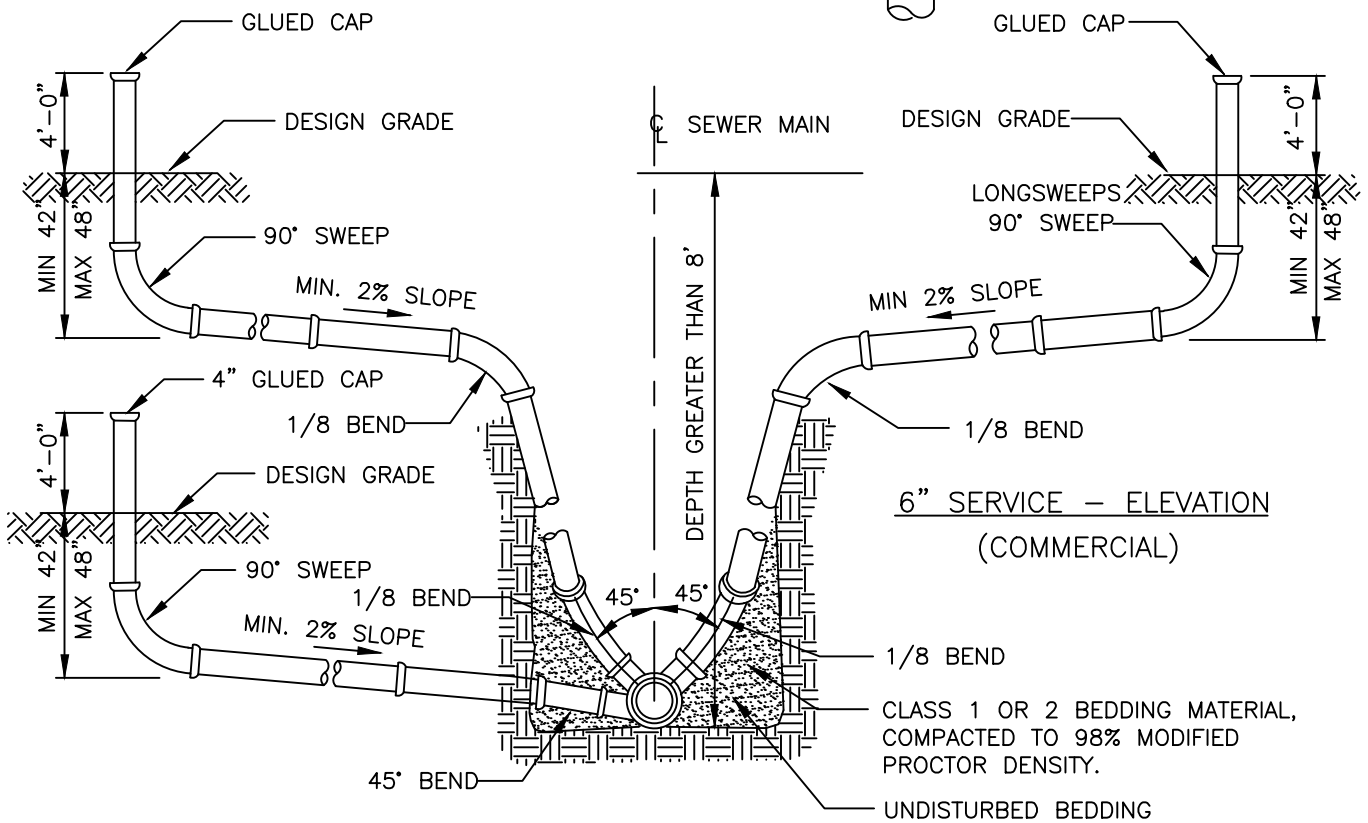
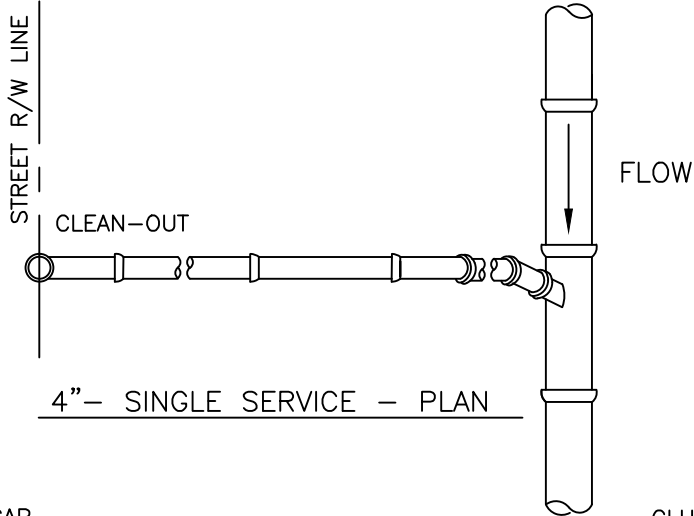

4" - 6" SINGLE SERVICE - ELEVATION

NOTES:

1. USE OF STYRENE MATERIAL WILL NOT BE PERMITTED.
2. ALL JOINTS TO BE RUBBER GASKET (NO GLUED FITTINGS) TYPICAL.
3. USE ALL HARCO SDR-26 FITTINGS OR CITY APPROVED EQUAL.

4" - RESIDENTIAL  
6" - COMMERCIAL



2023-01-25

STANDARD CONSTRUCTION DETAIL  
SEWER LATERAL DETAIL  
(SINGLE 4" RESIDENTIAL)  
(SINGLE 6" COMMERCIAL)

FILE NAME:

EW\_S10.DWG

DETAIL REF:

S-10

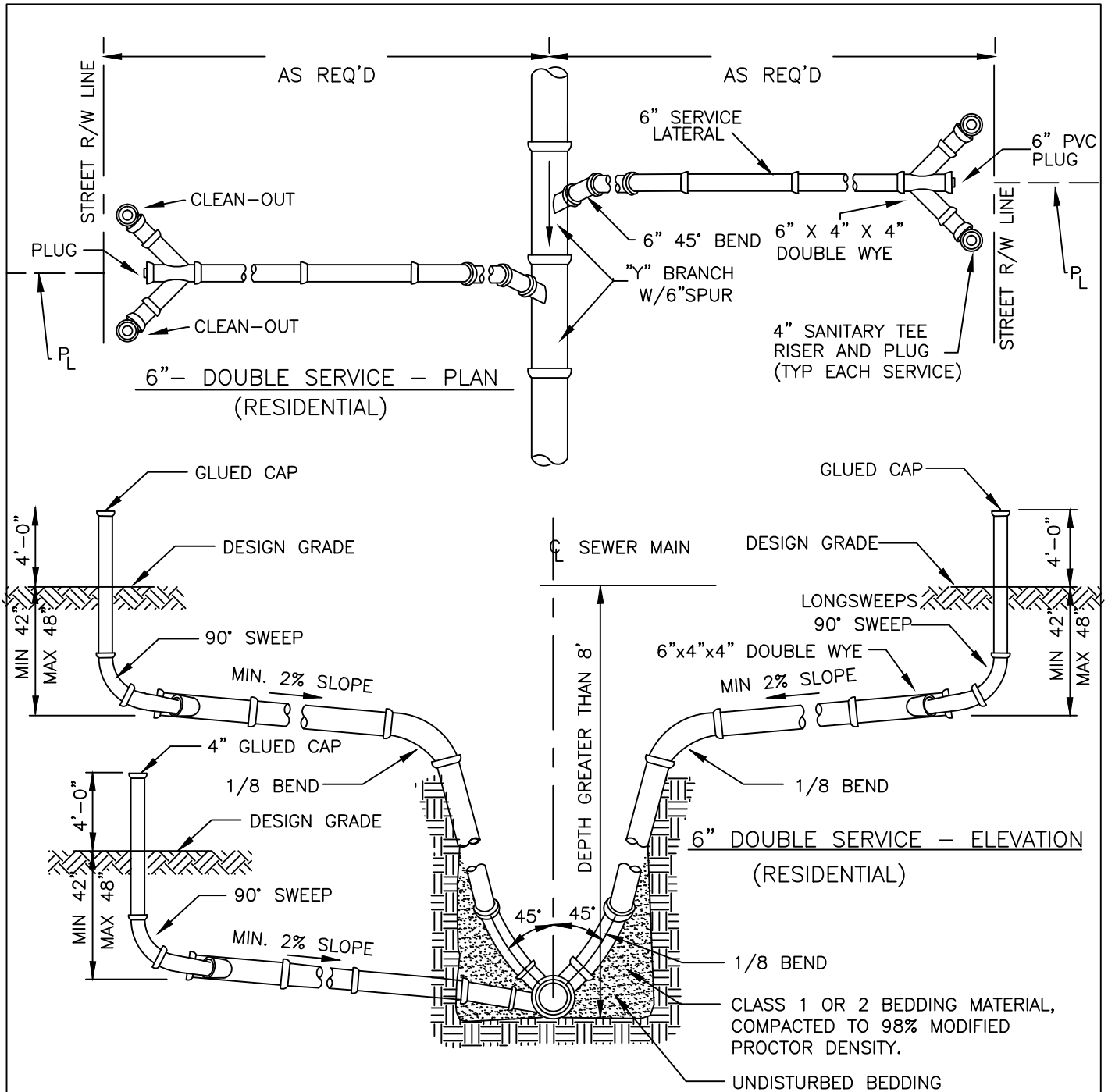

NOTE: SINGLE LATERALS SHALL BE INSTALLED ON ALL NEW RESIDENTIAL AND COMMERCIAL SEWER SYSTEMS. USE OF THIS DETAIL SHALL ONLY BE BY EXPRESS WRITTEN CONSENT OF THE TECHNICAL REVIEW COMMITTEE (TRC) AND INTENDED FOR RETROFIT APPLICATIONS ONLY.



2024-07-20

STANDARD CONSTRUCTION DETAIL  
SEWER LATERAL DETAIL  
(DOUBLE 6" RESIDENTIAL)

FILE NAME:

EW\_S11.DWG

DETAIL REF:

S-11

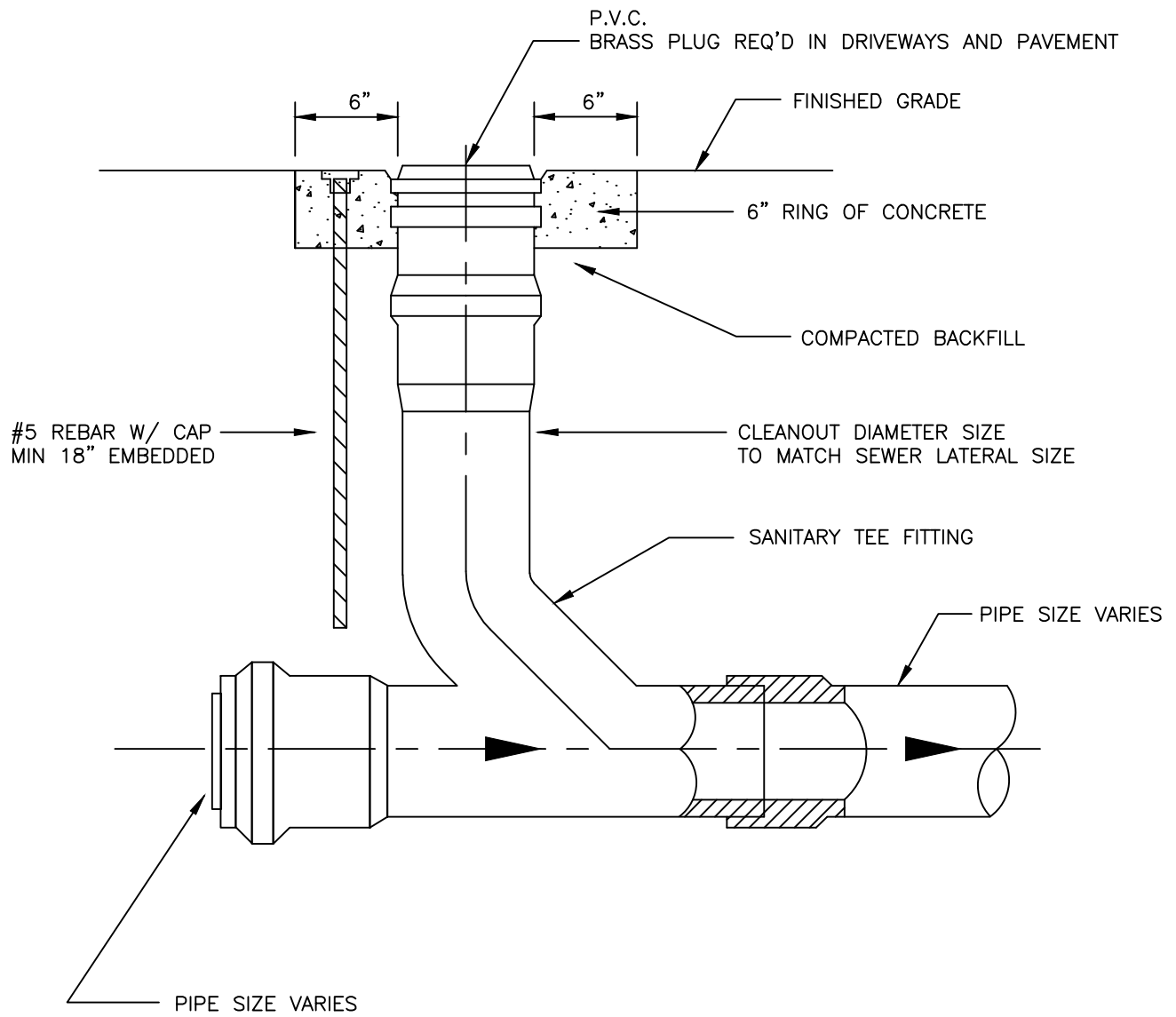

2023-01-25

STANDARD CONSTRUCTION DETAIL  
CLEANOUT DETAIL

FILE NAME:

EW\_S12.DWG

DETAIL REF:

S-12

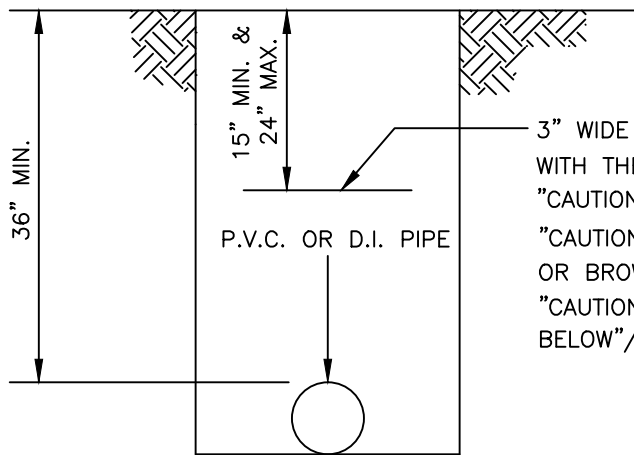

3" WIDE CONTINUOUS POLYETHYLENE TAPE WITH THE FOLLOWING LABELS AND COLORS:  
 "CAUTION BURIED WATER LINE BELOW"/BLUE  
 "CAUTION BURIED FORCEMAIN BELOW"/GREEN OR BROWN  
 "CAUTION BURIED RECLAIMED WATER LINE BELOW"/PURPLE

"TERRA TAPE D" or SIMILAR



2023-01-25

STANDARD CONSTRUCTION DETAIL  
 LOCATOR TAPE INSTALLATION FOR  
 SEWER, WATER AND RECLAIMED WATER PIPELINES

FILE NAME:

EW\_S13.DWG

DETAIL REF:

S-13

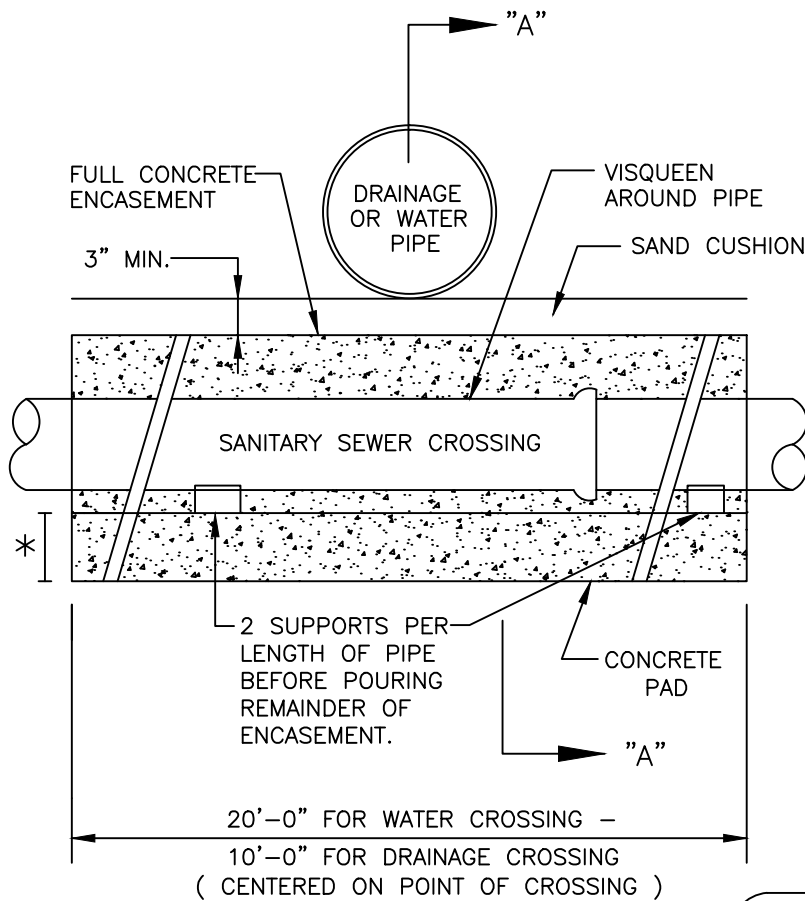

ELEVATION

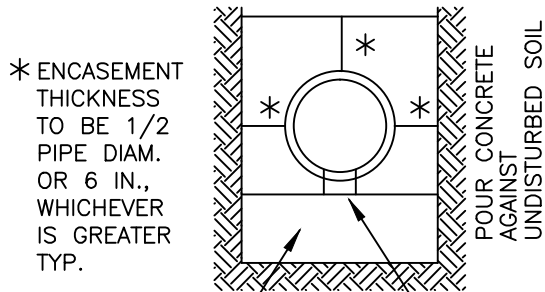
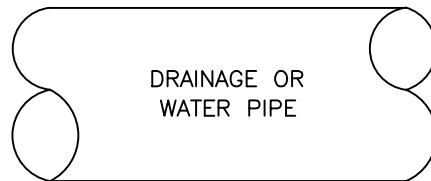

SECTION "A"-"A"

NOTES:

1. ALL CONCRETE SHALL BE 3000 PSI MINIMUM 28 DAYS STRENGTH.
2. WATER MAIN SHALL BE LOCATED ABOVE OR BELOW ENCASEMENT AS SHOWN ON PLANS OR DETERMINED IN THE FIELD, USE ENCASEMENT WHERE VERTICAL CLEARANCE WATER MAIN AND SEWER MAIN IS LESS THAN 12 INCHES.
3. NO DUCTILE IRON SEWER PIPE IS PERMITTED.
4. ENCASEMENT OF A.C. PIPE IS NOT ALLOWED REPLACE AFFECTED SECTIONS WITH PVC

FILE NAME:

EW\_S14.DWG

DETAIL REF:

S-14



2023-01-25

STANDARD CONSTRUCTION DETAIL  
SEWER CONDUIT CROSSING

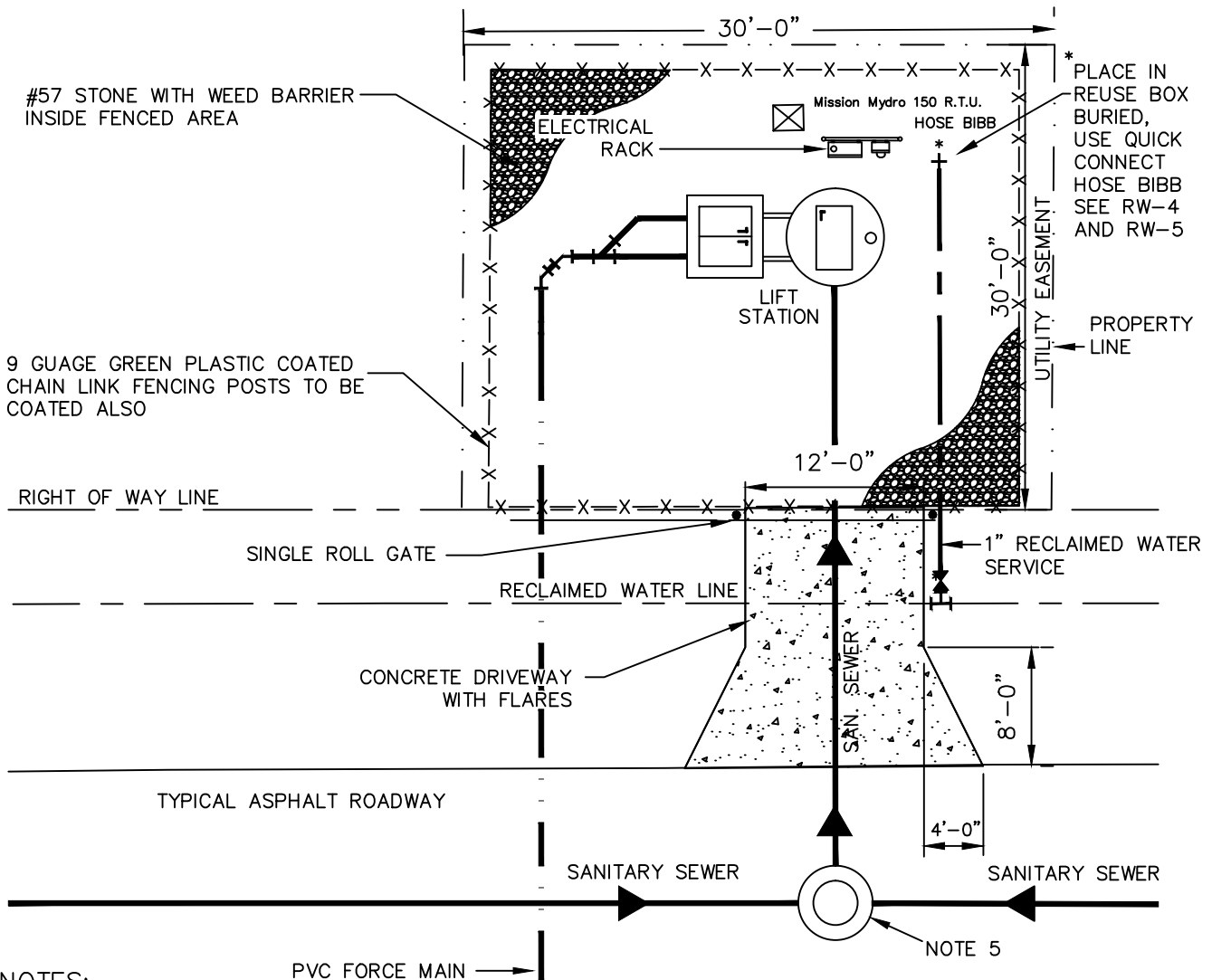

**NOTES:**

1. DRIVEWAY TO BE 6" THICK 3000 PSI CONCRETE AT 28 DAYS WITH 6x6 10/10 W.W. MESH. BASE TO BE COMPACTED AND TESTED TO 98% DENSITY WITH MINIMUM L.B.R. 40 BASED ON A.A.S.H.T.O. T-180 MODIFIED PROCTOR TEST.
2. IF RECLAIMED WATER IS UNAVAILABLE FOR LIFT STATION WATER SERVICE, CONTRACTOR SHALL USE POTABLE WATER.
3. REFER TO APPROPRIATE STANDARD CONSTRUCTION DETAIL FOR EMERGENCY PUMP CONNECTION/PLUG VALVE DETAIL AND LIFT STATION WATER SERVICE DETAIL
4. FENCE MAY BE RELOCATED INTERNALLY WITHIN SITE TO CREATE A 25' X 25' SITE IF LANDSCAPING MATERIALS ARE INSTALLED AROUND THE PERIMETER.
5. MANHOLE TO BE LINED, "AGRU" OR APPROVED EQUAL.
6. LANDSCAPING SHALL CONSIST OF #57 WHITE ROCK. BUSHES, ACCEPTABLE TO THE CITY, SHALL BE PLACED AS A VISUAL BUFFER TO ANY RESIDENTIAL AREAS ADJACENT TO THE LIFT STATION.
7. INSIDE FENCE AREA, STOP DRIVEWAY AT FENCE LINE AND ADD FOUR INCHES OF #57 STONE ON INSIDE OF FENCE AREA WITH WEED BARRIER UNDERNEATH. OUTSIDE OF FENCE AREA TO BE SODDED.
8. FENCING SHALL BE 6' HIGH WITH SINGLE ROLL GATE. NOT SWING GATE.
9. EQUIP WITH AN EMERGENCY POWER PERMANENTLY INSTALLED DIESEL DRIVEN BYPASS PUMP MANUFACTURED BY ATLAS COPCO.

\* IF RECLAIMED SVC. IS UNAVAILABLE, USE DETAIL #S-16 FOR WATER SERVICE



2023-01-25

STANDARD CONSTRUCTION DETAIL  
TYPICAL LIFT STATION SITE PLAN

FILE NAME:

EW\_S15.DWG

DETAIL REF:

S-15



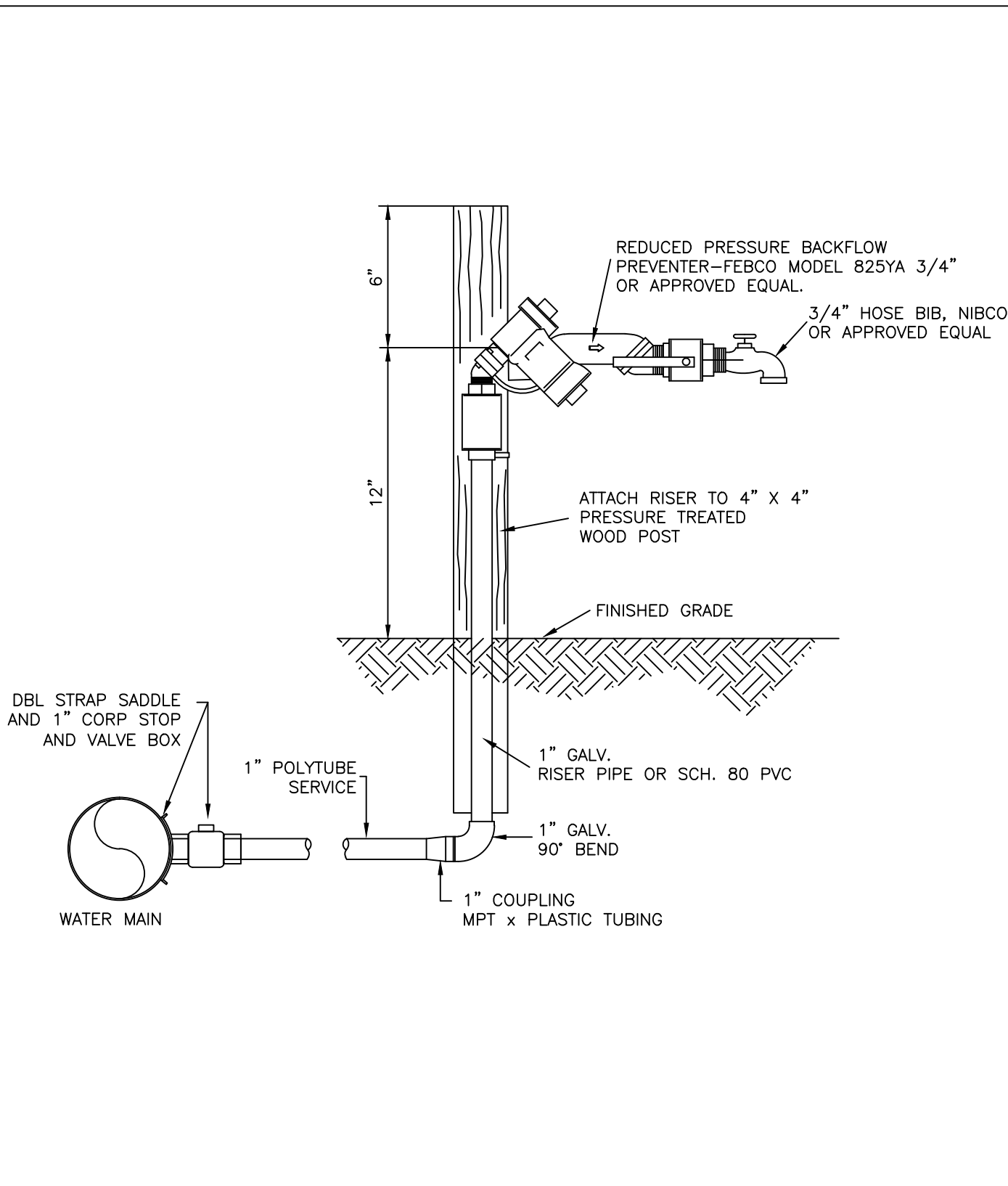

2023-01-25

STANDARD CONSTRUCTION DETAIL  
 LIFT STATION POTABLE WATER SERVICE  
 (WHERE RECLAIMED WATER NOT AVAILABLE)

FILE NAME:

EW\_S16.DWG

DETAIL REF:

S-16

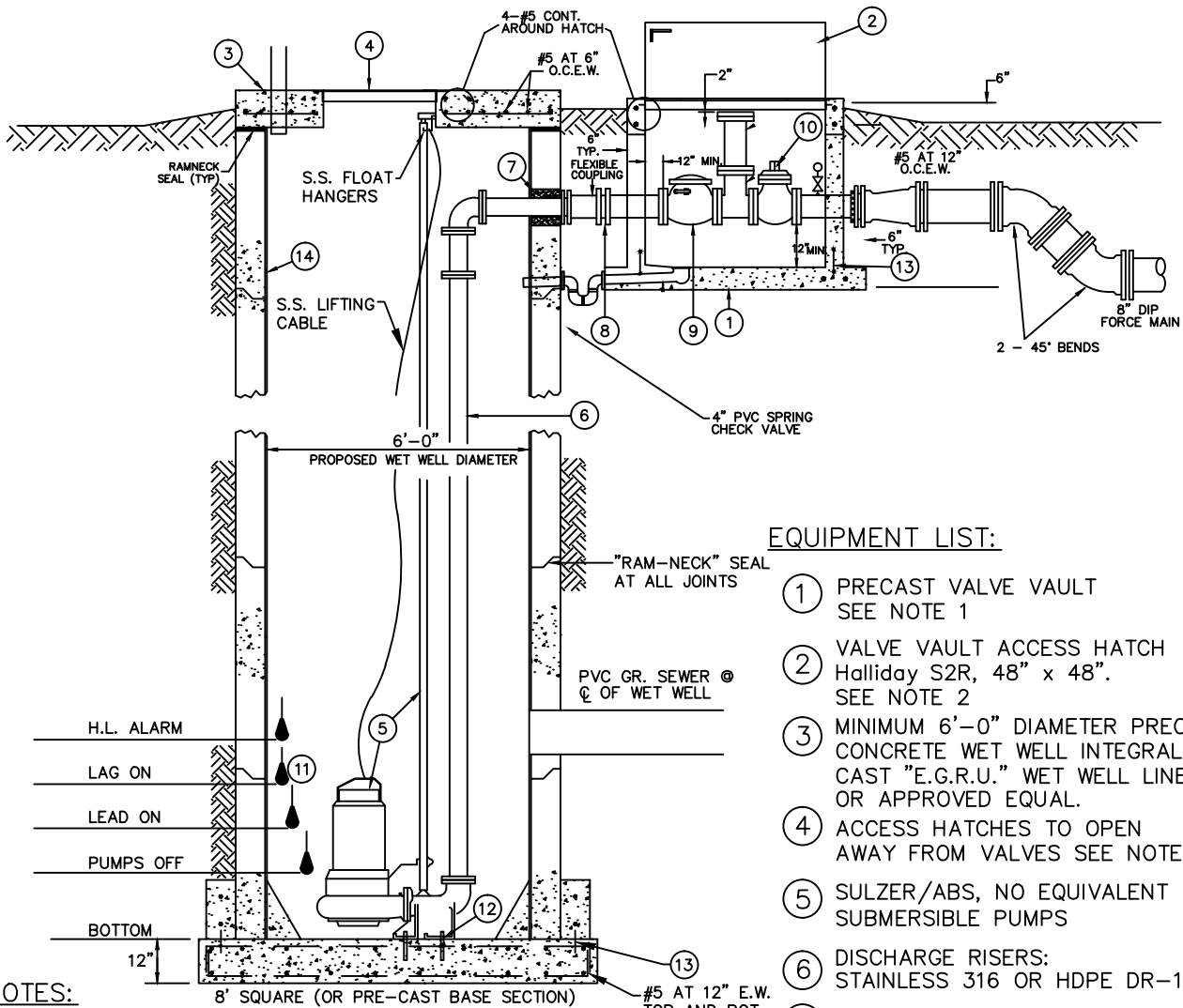

**EQUIPMENT LIST:**

- ① PRECAST VALVE VAULT  
SEE NOTE 1
- ② VALVE VAULT ACCESS HATCH  
Halliday S2R, 48" x 48".  
SEE NOTE 2
- ③ MINIMUM 6'-0" DIAMETER PRECAST  
CONCRETE WET WELL INTEGRALLY  
CAST "E.G.R.U." WET WELL LINER  
OR APPROVED EQUAL.
- ④ ACCESS HATCHES TO OPEN  
AWAY FROM VALVES SEE NOTE 2.
- ⑤ SULZER/ABS, NO EQUIVALENT  
SUBMERSIBLE PUMPS
- ⑥ DISCHARGE RISERS:  
STAINLESS 316 OR HDPE DR-13
- ⑦ GROUT SEAL AROUND DISCHARGE  
LINES WITH NON-SHRINK GROUT
- ⑧ FLEXIBLE COUPLING APPROVED BY  
THE CITY ENGINEER
- ⑨ FL. x FL. CHECK VALVE
- ⑩ FL. x FL. PLUG VALVE W/  
VALVE WRENCH
- ⑪ 4 FLOATS FOR PUMP CONTROL  
COORDINATE ELEV. WITH CITY
- ⑫ ANCHOR PUMP TO WET WELL FLOOR
- ⑬ 6" PVC WATER STOP
- ⑭ "E.G.R.U." LINER JOINTS TO BE FIELD  
WELDED

**NOTES:**

- 1. INTERIOR OF VALVE VAULT AND ALL PIPING AND FITTINGS SHALL BE DELIVERED WITH A FACTORY APPLIED EPOXY FINISH.
- 2. COORDINATE WET WELL ACCESS HATCH LOCATION WITH PUMP MOUNTING LOCATIONS. HATCH TYPE HALLIDAY S1R/S2R PROVIDE LOCKING POST TYPE MECHANISM AND SAFETY GRATING ON ALL ACCESS HATCHES. ALL HATCHES TO BE 300 P.S.F. LOAD RATED.
- 3. SEE SPECIFICATIONS FOR APPROVED VALVE TYPES AND MANUFACTURERS.
- 4. SOD ALL AREAS DISTURBED BY CONSTRUCTION ACTIVITIES OUTSIDE OF FENCED AREA.
- 5. SULZER/ABS, NO EQUIVALENT PUMPS TO BE FURNISHED WITH DISCHARGE CONNECTION COUPLING, STAINLESS STEEL SLIDERAIL SYSTEM, SEAL FAILURE AND THERMAL OVERLOAD INDICATORS.
- 6. ALL PIPES, INVERTS AND HATCHES TO BE THE SIZE AND KIND SPECIFIED ON THE SET OF APPROVED CONSTRUCTION PLANS.
- 7. ALL HARDWARE INSIDE WETWELL SHALL BE 316SS.
- 8. ALL PRESSURE PIPING TO BE RESTRAINED W/MEGALUG FITTINGS OR EQUAL.



2024-07-20

STANDARD CONSTRUCTION DETAIL  
LIFT STATION WET WELL  
SECTION  
(SUBMERSIBLE)

FILE NAME:

EW\_S17.DWG

DETAIL REF:

S-17



2023-01-25

STANDARD CONSTRUCTION DETAIL  
LIFT STATION  
PLAN VIEW  
(SUBMERSIBLE)

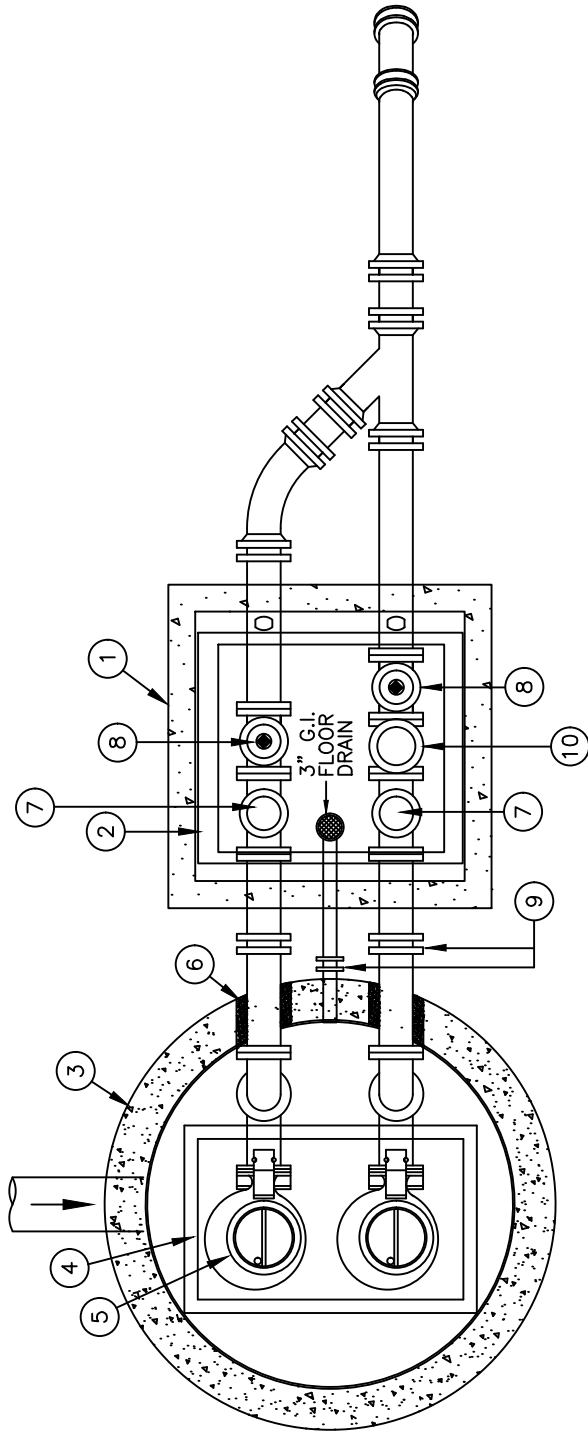

PLAN VIEW  
N.T.S.

EQUIPMENT LIST

- ① PRECAST VALVE VAULT SEE NOTE 1
- ② VALVE VAULT ACCESS HATCH U.S. FOUNDRY APD300 48x48, SEE NOTE 2
- ③ 6'-0" DIAMETER PRECAST CONCRETE WET WELL INTEGRALLY CAST "E.G.R.U." WET WELL LINER
- ④ WET WELL ACCESS HATCHES, SEE NOTE 2
- ⑤ FLGYT OR ABS SUBMERSIBLE PUMPS.
- ⑥ GROUT SEAL AROUND DISCHARGE LINES WITH NON-SHRINK GROUT
- ⑦ FL. x FL. CHECK VALVE
- ⑧ FL. x FL. 1/4 TURN PLUG VALVE W/ VALVE WRENCH
- ⑨ M.J. X M.J. SLEEVE W/ MEGALUG RESTRAINT
- ⑩ EMERGENCY PUMP CONNECTION

NOTES:

- 1. SANDBLAST AND PAINT INTERIOR OF VALVE VAULT PRE-COAT EPOXY FROM MANUFACTURER OR 2 COATS - 15 MILS TOTAL OF APPROVED COATING.
- 2. COORDINATE WET WELL ACCESS HATCH LOCATION WITH PUMP MOUNTING LOCATIONS. PROVIDE HASP TYPE LOCKING MECHANISM ON ALL ACCESS HATCHES. ALL HATCHES TO BE 300 P.S.F. LOAD RATED.
- 3. SEE SPECIFICATIONS FOR APPROVED VALVE TYPES AND MANUFACTURERS.
- 4. PUMPS TO BE FURNISHED WITH HIGH PRESSURE DISCHARGE COUPLING, STAINLESS STEEL SLIDERAIL SYSTEM, SEAL FAILURE AND THERMAL OVERLOAD INDICATORS.
- 5. ALL PIPES, INVERTS AND HATCHES TO BE THE SIZE AND KIND SPECIFIED ON THE SET OF APPROVED CONSTRUCTION PLANS.
- 6. ALL HARDWARE INSIDE WETWELL TO BE 316 STAINLESS STEEL.
- 7. ALL PRESSURE PIPING TO BE RESTRAINED W/MEGALUG FITTINGS OR EQUAL.
- 8. PRESSURE GUAGE TO BE INSTALLED ON DISCHARGE SIDE OF PLUG VALVE, OPPOSITE SIDE OF BYPASS. USE DIAPHRAGM STYLE GUAGE ASSEMBLY.

FILE NAME:

EW\_S18.DWG

DETAIL REF:

S-18

LIFT STATION WET WELL DESIGN AND CONSTRUCTION NOTES  
FOR SUBMERSIBLE PUMP STATIONS

1. SEE CITY STANDARD DETAIL FOR EMERGENCY PUMP CONNECTION REQUIREMENTS
2. SEE CITY STANDARD DETAIL FOR 1" HOSE BIBB AND REQUIREMENTS.
3. SEE CITY STANDARD DETAIL FOR ALL ELECTRICAL REQUIREMENTS.
4. MINIMUM WET WELL DIAMETER IS 6 FT. THE MINIMUM REQUIRED DEPTH OF WET WELL BELOW THE LOWEST INVERT, SHOULD BE SET TO ALLOW THE MINIMUM RUN AND CYCLE TIMES OF THE PUMPS.
5. ALL PIPING SHALL BE HDPE AND FITTINGS IN WET WELL TO BE EPOXY LINED AND ASSEMBLED WITH 316SS STAINLESS STEEL BOLTS AND NUTS ONLY.
6. STATION TOP TO BE AT 1" ABOVE FINISHED GRADE AND TAPERED TO FINISHED GRADE AND ITS ELEVATION WILL BE NO LOWER THAN 0.5-FT ABOVE THE 100-YEAR BASE FLOOD ELEVATION.
7. ALL DISCHARGE FITTINGS ON THE EXIT SIDE OF THE VALVE VAULT WILL BE PVC RESTRAINED JOINT.
8. ALL SEWER LINES ENTERING AND EXITING MANHOLES SHALL BE SEALED UTILIZING RUBBER BOOTS OR OTHER CITY APPROVED INFILTRATION LIMITING METHOD
9. WET WELL SECTIONS SHALL BE JOINED USING RAMNECK JOINT MATERIAL AND SHALL BE FREE FROM SEEPAGE PRIOR TO ACCEPTANCE. PROVIDE EZ-WRAP BUTYL ADHESIVE TAPE PER MANUFACTURERS RECOMMENDATIONS AT EACH WET WELL SECTION EXTERIOR JOINT CIRCUMFERENCE. USE EASY STICK NO.4 PRIMER PER MANUFACTURERS RECOMMENDATIONS PRIOR TO INSTALLATION OF EZ-WRAP TAPE.
10. NO SPLICES OR JUNCTION BOXES ARE ALLOWED FOR BALL FLOAT CORD INSTALLATION.
11. ALL LIFT STATIONS SHALL BE FIBERGLASS LINED OR LINED WITH ANOTHER MATERIAL AS APPROVED BY THE CITY (ASTM d 3753)
12. WET WELL CONSTRUCTION SHALL BE REINFORCED CONCRETE IN ACCORDANCE WITH ASTM C-76 4000PSI AT 28 DAYS. ALTERNATE CONSTRUCTION SHALL BE PRECAST MONOLITHIC WITH BASE SLAB IN ACCORDANCE WITH ASTM C-478.
13. ELECTRICAL PERMIT TO BE OBTAINED FROM THE CITY PRIOR TO BEGINNING WORK ON ANY ELECTRICAL WIRING, EQUIPMENT, ETC. ALL ELECTRICAL WIRING TO COMPLY WITH THE CURRENT NATIONAL ELECTRIC CODE.
14. THREE COPIES OF THE LIFT STATION OPERATING MANUAL TO BE PROVIDED TO THE ENVIRONMENTAL SERVICES DEPARTMENT PRIOR TO FINAL ACCEPTANCE OF THE LIFT STATION.
15. EMERGENCY HIGH LEVEL WETWELL FLASHING RED LIGHT REQUIRED WITH AUDIBLE ALARM (SEE S-20 NOTES)
16. LINKABLE FUSED ELECTRICAL DISCONNECT REQUIRED.
17. ALL PUMP STATION WIRING SHALL BE STANDARD COPPER.
18. THREE PHASE POWER AND MOTORS REQUIRED. VOLTAGE TO BE CONFIRMED BY CITY ENGINEER.
19. DISCONNECT FOR MISSION MYDRO 150 RTU TELEMETRY TO BE PROVIDED.
20. FLOAT HANGER WILL BE INSTALLED AVOIDING ALL CONFLICTS WITH ANY INVERTS.
21. 2 IN. CONDUIT SHALL BE INSTALLED FOR FLOAT WIRES. EACH PUMP CORD SHALL HAVE A SEPARATE 2" CONDUIT.
22. ALL PUMPS WILL BE SPACED AND SET PER PUMP MANUFACTURERS SPECIFICATIONS.
23. ALL PUMP GUIDE RAILS WILL BE 316SS STAINLESS STEEL OR APPROVED EQUAL.
24. ALL WET WELL FLOORS WILL BE SLOPED TO AVOID ANY SETTLEMENT OF SOLIDS.
25. ALL VALVE VAULT FLOORS WILL BE SLOPED AND PITCHED TOWARD THE FLOOR DRAIN.
26. A MINIMUM OF 95% DENSITY SUBBASE REQUIRED FOR ALL STRUCTURES. (WET WELL VALVE VAULT, ETC.)
27. AFTER DENSITY IS ACHIEVED, A 1 FT. BED OF #57 STONE WILL BE PLACED BETWEEN EARTH AND STRUCTURE.
28. CONTRACTOR MUST PROVIDE A POST CONSTRUCTION VIDEO OF ALL MANHOLES AND GRAVITY SEWER LINES, INCLUDING ALL MAINS AND LATERALS.
29. A DIAPHRAGM STYLE PRESSURE GAUGE WILL BE INSTALLED ON THE DISCHARGE SIDE OF THE PLUG VALVE. INSTALLATION WILL BE A STAINLESS STEEL SADDLE TAP METHOD, AND EQUIPPED WITH A BRASS BALL VALVE BETWEEN THE GAUGE AND THE PIPE.
30. ALL PUMP STATIONS SHALL HAVE PERMINATELY INSTALLED DIESEL DRIVEN ATLAS COPCO BYPASS PUMP AND A HUBBELL CONNECTION ON THE EXTERIOR OF THE ELECTRICAL PANEL SUFFICIENT FOR GENERATOR POWER.



2024-07-20

STANDARD CONSTRUCTION DETAIL  
LIFT STATION WET WELL DESIGN AND  
CONSTRUCTION NOTES  
(SUBMERSIBLE PUMP STATIONS)

FILE NAME:

EW\_S19.DWG

DETAIL REF:

S-19

EMERGENCY PUMP CONNECTION AND BOX  
 4" OR 6" BRANCH AND 4" RISER, FEMALE  
 CAM-LOCK FITTING AND DUST PLUG

6" OR 4" RESILIENT SEAT  
 GATE VALVE AND BOX

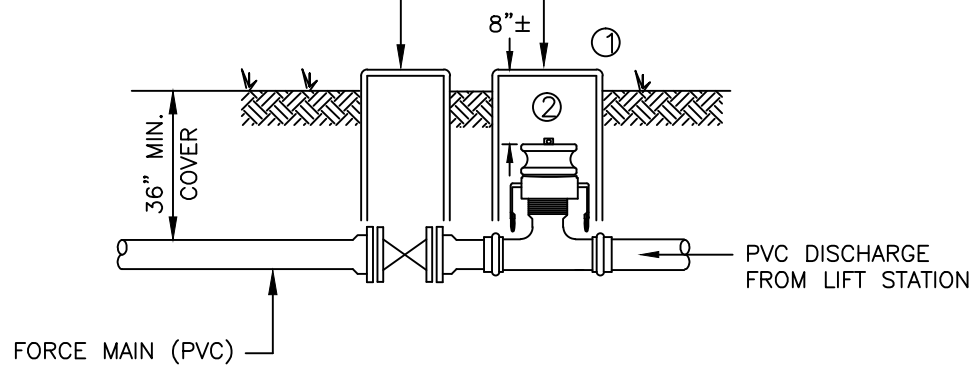

NOTES:

1. PUMP CONNECTION BOX IS CDR #WB001527-12. SOLID 15" X 27" COVER WITH "SEWER" IMPRINTED ON LID.
2. CAM-LOK PIPE FITTING IS 4" MIPX MALE CAMLOCK WITH FEMALE DUST PLUG.



2024-07-20

STANDARD CONSTRUCTION DETAIL  
 LIFT STATION  
 EMERGENCY PUMP CONNECTION

FILE NAME:

EW\_S20.DWG

DETAIL REF:

S-20

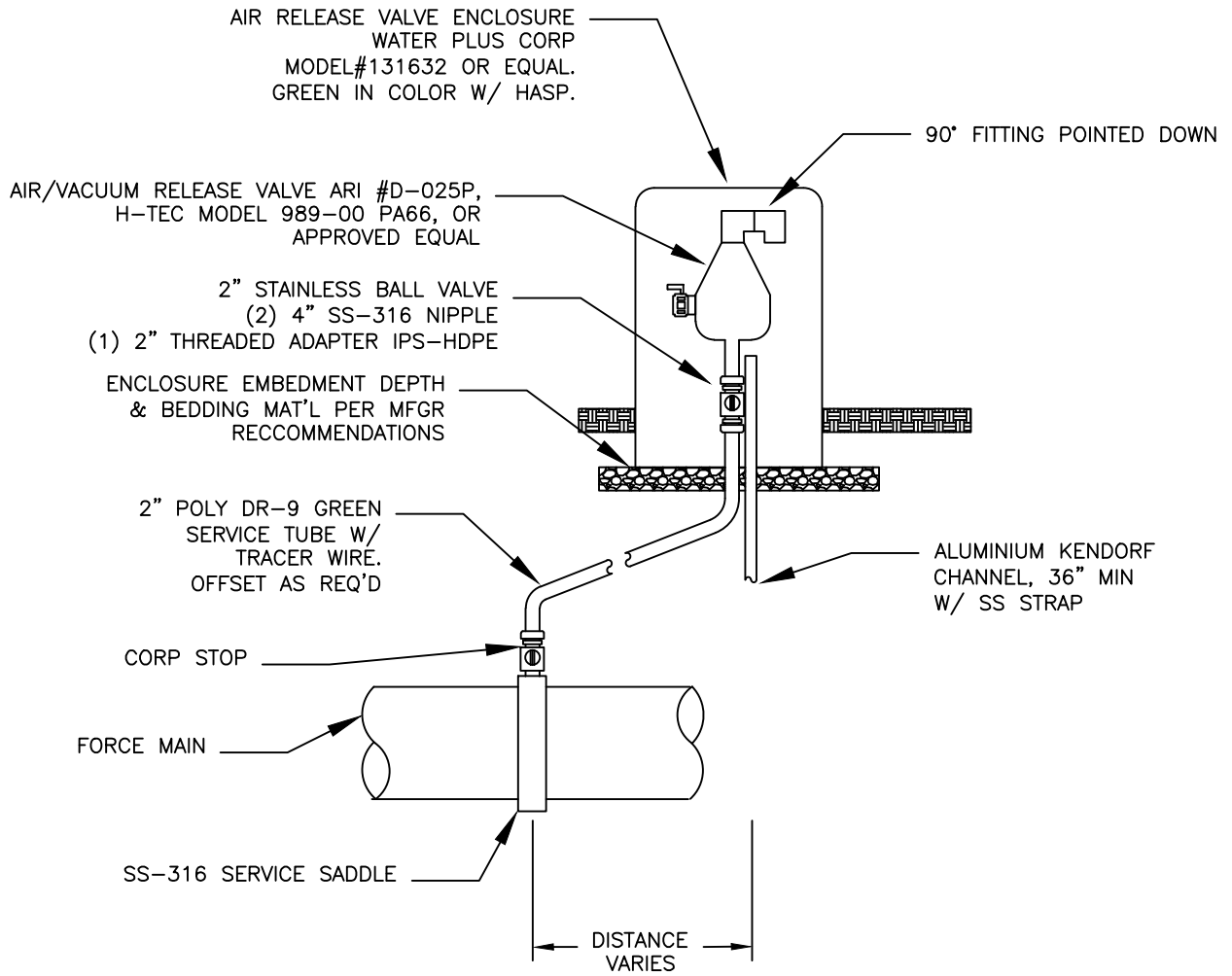
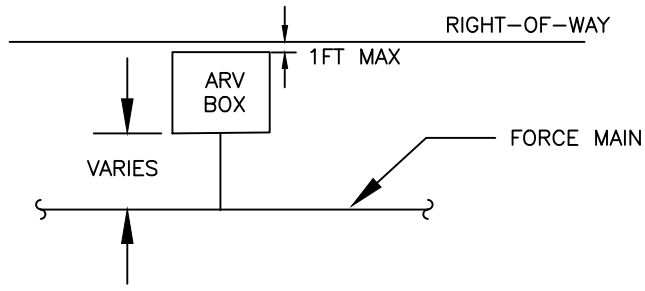

2024-07-20

STANDARD CONSTRUCTION DETAIL  
AIR RELEASE VALVE ON SANITARY FORCE MAIN

|             |            |
|-------------|------------|
| FILE NAME:  | EW_S21.DWG |
| DETAIL REF: | S-21       |

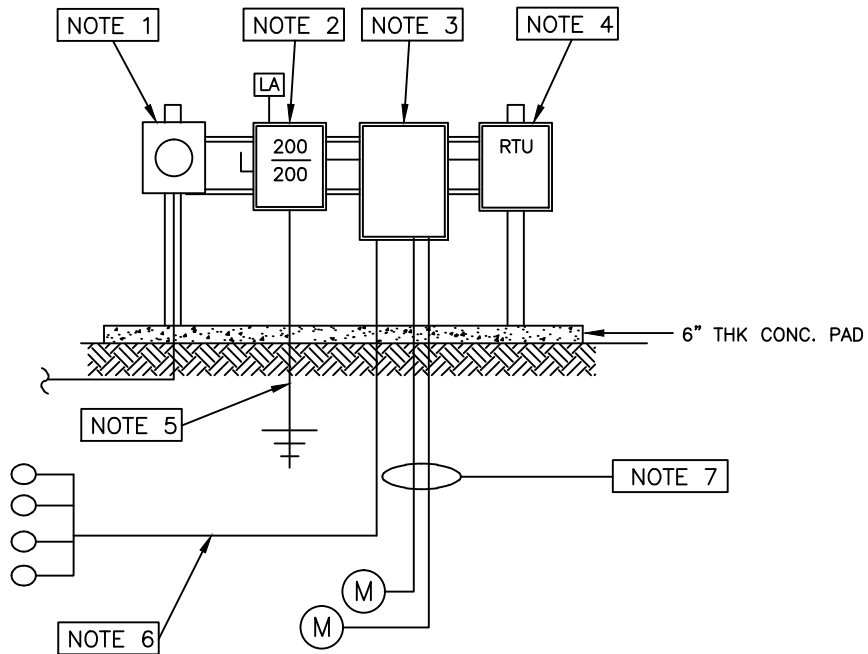

NOTES:

1. FPL APPROVED METER CAN WITH BYPASS
2. ELECTRICAL DISCONNECT SIZED TO STATION
3. ELECTRICAL PANEL FOR A SUBMERSABLE STATION OR MANUAL TRANSFER SWITCH FOR A WETWELL MOUNTED STATION.
4. RTU 24X24X9
5. #4 SOLID GROUND WIRE CONNECTED TO 3 8-FOOT GROUND RODS SPACED 10 FEET APART
6. 2 INCH SCH.80 PVC WITH 4 FLOAT SWITCHES
7. 2 INCH SCH.80 PVC WITH 1 PUMP LEAD IN EACH CONDUIT.
8. ALL CONDUITS CONNECTING THE WETWELL TO AN ELECTRICAL APPLIANCE WILL BE PROTECTED BY SEAL OFFS
9. ELECTRICAL PANEL WILL BE BUILT WITH 2 EXTRA 120V POWER POINTS
10. REQUIREMENTS FOR THE ELECTRICAL PANEL COMPONENTS ARE NOTED IN DETAILS S-22A, AND S-22B
11. ALL WIRING COMPONENTS AND STRUCTURES WILL BE IN COMPLIANCE WITH THE NATIONAL ELECTRIC CODE
12. ALL ELECTRICAL APPLIANCED WILL BE NEMA RATED 316 STAINLESS STEEL
13. GENERATOR RECEPTICAL WILL BE A HUBBEL 4100B9W 4PIN 100 AMP WITH WEATHERPROOF CAP
14. TELEMETRY AND LEVEL CONTROL DEVICES WILL BE MISSION MYDRO 150
15. PROVIDE 3IN. ALUMINUM PIPES OR 6in X 6in CEMENT POST AND 1/3 CUBIC YARD OF CEMENT TO SUPPORT EQUIPMENT RACK ASSEMBLY. EQUIPMENT RACK ASSEMBLY TO INCLUDE 1 1/2in STAINLESS STEEL KINDORF CHANNEL USING STAINLESS STEEL HARDWARE. (U-BOLTS, BOLTS, ETC)
16. CONTRACTOR WILL BE REQUIRED TO APPLY FOR ALL APPLICABLE PERMITS
17. LIGHTNING ARRESTOR - SQUARE D. NO. SDSA 3650 TO BE INSTALLED IN PANEL
18. ALL LIFT STATIONS WITH ALARM LIGHT AND AUDIBLE ALARM TO BE INSTALLED ON ELECTRICAL PANEL



2024-07-20

STANDARD CONSTRUCTION DETAIL  
PACKAGED LIFT STATION  
ELECTRICAL EQUIPMENT RACK

FILE NAME:

EW\_S22.DWG

DETAIL REF:

S-22

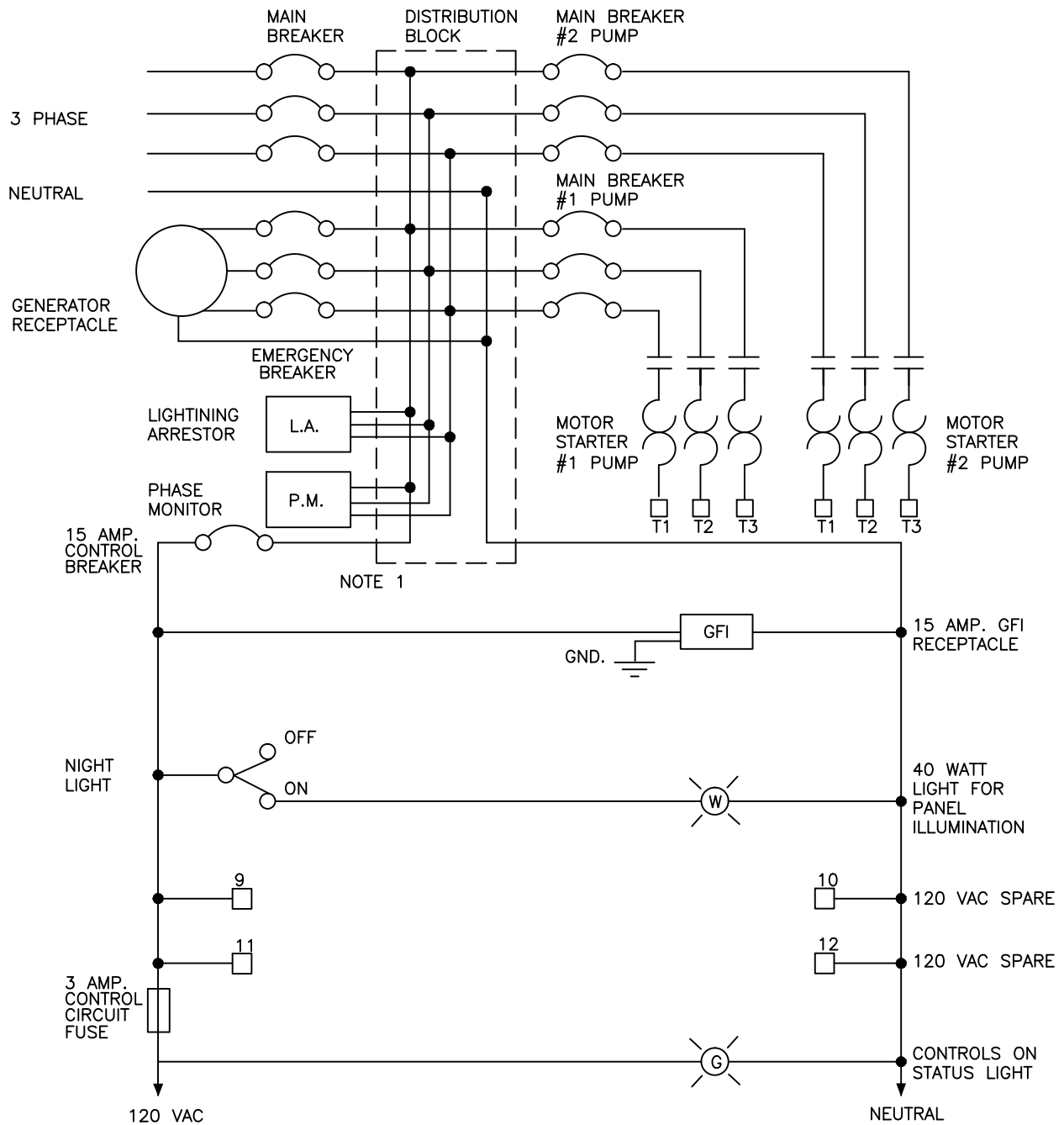

NOTE 1 - FOR 277/480 VOLT PANELS STEP DOWN TRANSFORMER FOR 120 VOLT CONTROL VOLTAGE WILL BE REQUIRED.



2023-01-25

STANDARD CONSTRUCTION DETAIL  
 PACKAGED LIFT STATION  
 ELECTRICAL PANEL SCHEMATIC

FILE NAME:  
 EW\_S22A.DWG

DETAIL REF:

S-22A



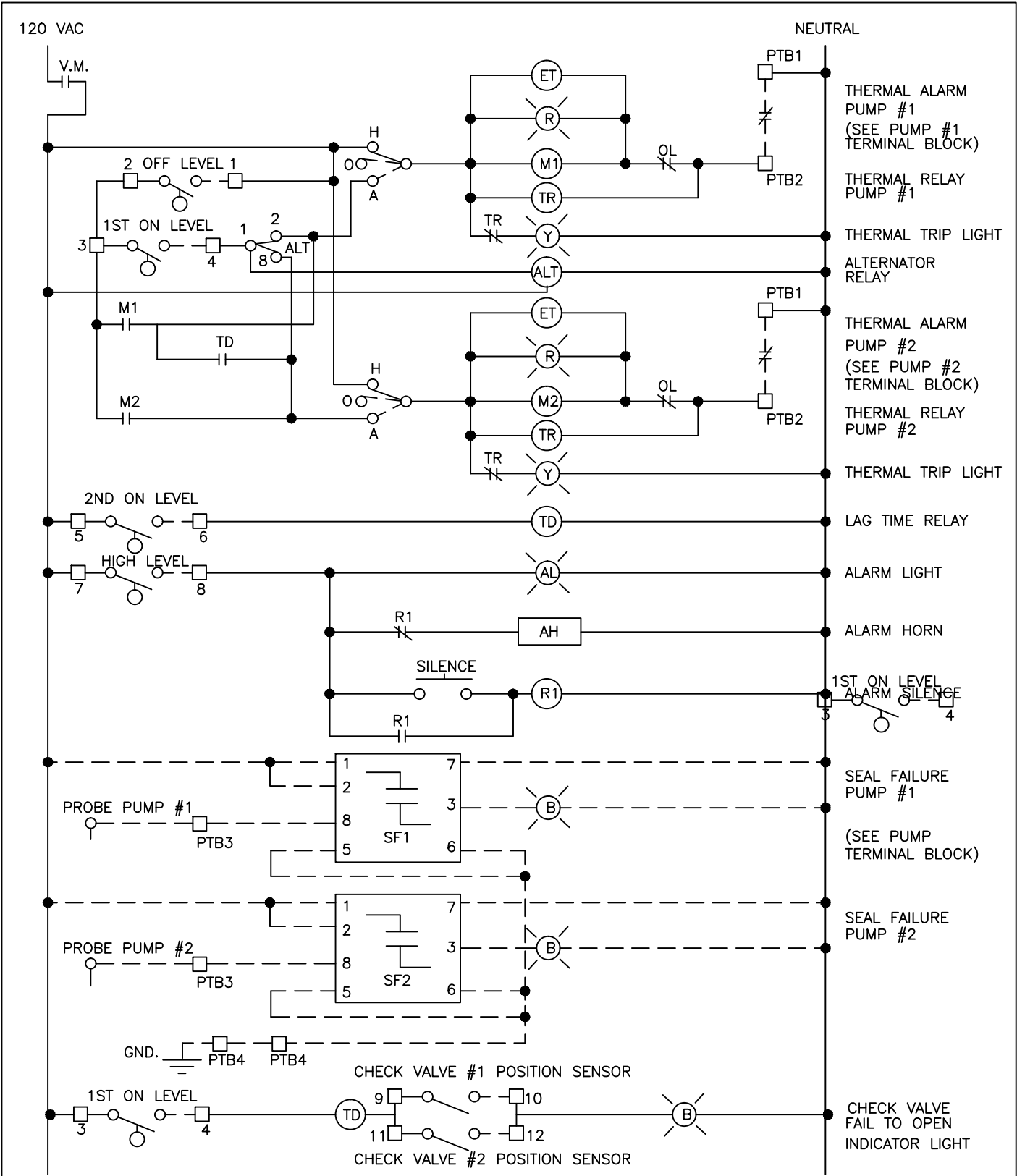

2024-07-20

STANDARD CONSTRUCTION DETAIL  
 PACKAGED LIFT STATION  
 ELECTRICAL PANEL SCHEMATIC

FILE NAME:  
 EW\_S22B.DWG

DETAIL REF:  
 S-22B

PLAN VIEW

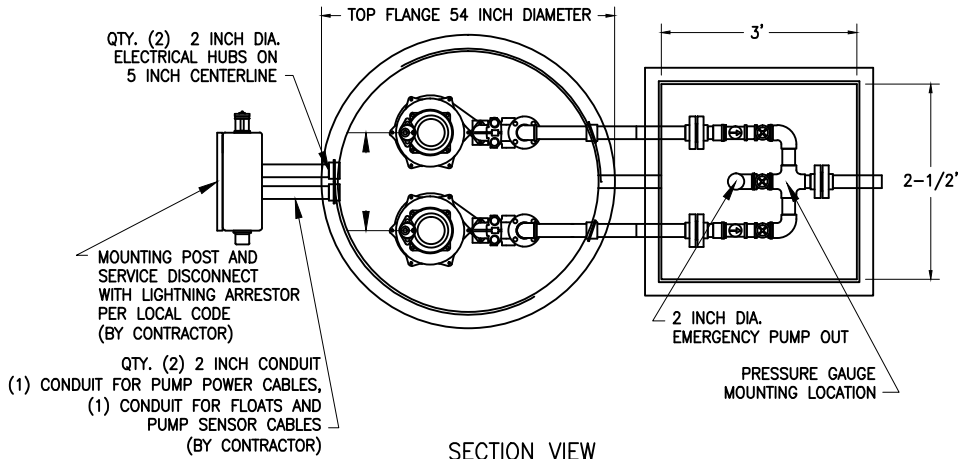

SECTION VIEW

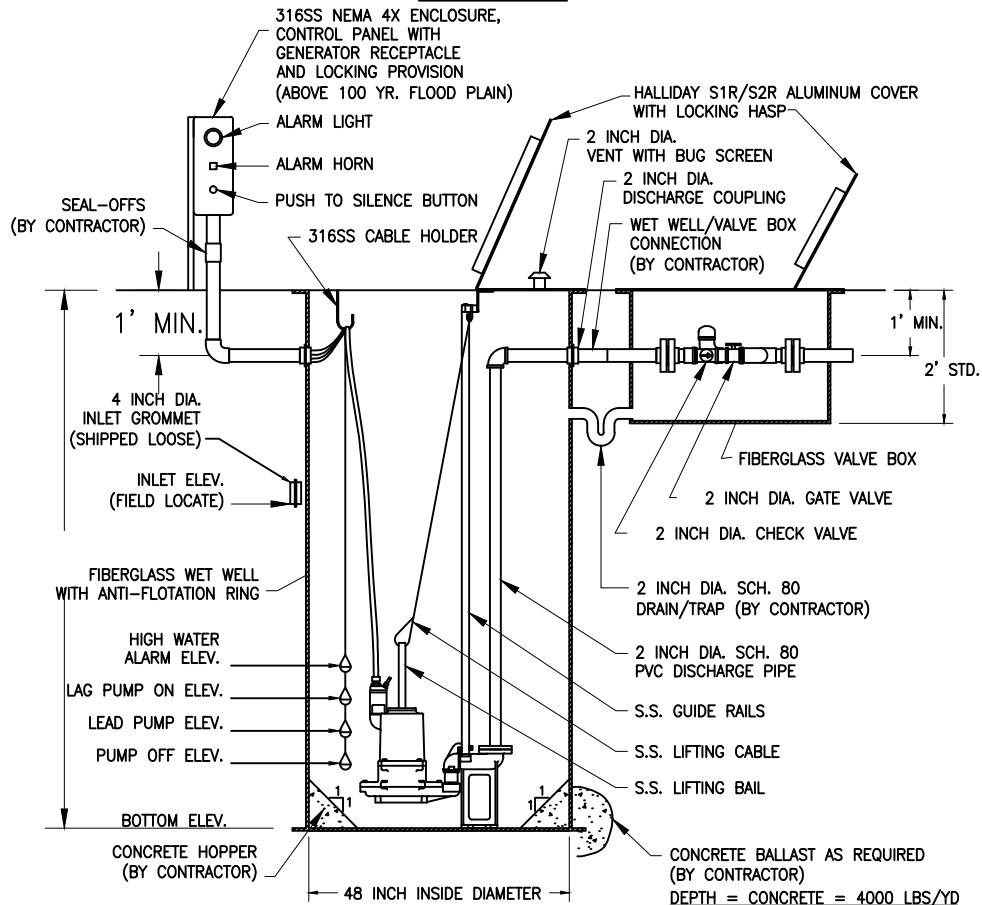

DEPTH = CONCRETE = 4000 LBS/YD  
 6FT = 1.5 YDS (6000 LBS)  
 8FT = 2 YDS (8000 LBS)  
 10FT = 2.5 YDS (10000 LBS)  
 12FT = 3 YDS (12000 LBS)  
 14FT = 3.5 YDS (14000 LBS)

NOTES:

1. USE ONLY WITH SPECIFIC APPROVAL FROM UTILITY DEPT.
2. PRESSURE AND FLOW CONDITIONS TO BE DETERMINED BY DESIGN ENGINEER.



2023-01-25

STANDARD CONSTRUCTION DETAIL  
 UNITARY SEWAGE PUMP STATION

FILE NAME:

EW\_S22C.DWG

DETAIL REF:

S-22C

SANITARY SEWER DESIGN AND CONSTRUCTION NOTES

1. THE CITY'S ENVIRONMENTAL SERVICES DEPT. (424-2400 X4007) SHALL BE GIVEN A MINIMUM OF 2 BUSINESS DAYS ADVANCE NOTICE (NOT INCLUDING HOLIDAYS OR WEEKENDS) PRIOR TO BEGINNING ANY SANITARY SEWER CONSTRUCTION.
2. ALL GRAVITY SANITARY SEWER MAIN LINES SHALL BE 8" DIAMETER MINIMUM. COMMERCIAL SERVICE LATERALS WITH MULTIPLE CONNECTIONS SHALL BE GREEN 6" DIA. OR LARGER. ALL SINGLE FAMILY RESIDENTIAL SERVICE LATERALS SHALL BE 4" - SINGLE SERVICES.
3. ALL GRAVITY SANITARY SEWER LINES SHALL BE GREEN PVC SDR 26, ASTM D-3034. IN PLACES WHERE A MINIMUM COVER OF 4.0' CANNOT BE MAINTAINED, AWWA C-900 OR C-905 GREEN PVC DR-25, CLASS 100 OR CONCRETE ENCASEMENT SHALL BE USED. WATER LINES, RECLAIMED LINES, AND STORM DRAINAGE CROSSINGS SHALL ALSO FOLLOW THE CONCRETE ENCASEMENT REQUIREMENT PER THESE STANDARDS AND AS PER REGULATORY REQUIREMENTS.
4. MINIMUM GRAVITY SANITARY SEWER SLOPES ARE AS FOLLOWS:  
8" PIPE 0.40 %  
10" PIPE 0.30%  
12" PIPE 0.22%
5. GRAVITY SANITARY SEWER LINES SHALL BE INSTALLED WHENEVER POSSIBLE UNDER PAVED AREAS WITHIN PUBLIC RIGHTS-OF-WAY. UTILITY EASEMENTS SHALL BE PROVIDED WHENEVER PUBLICLY-OWNED SEWER LINES ARE CONSTRUCTED OUTSIDE OF A PUBLIC RIGHT-OF-WAY.
6. GRAVITY SANITARY SEWER LINE CONSTRUCTION SHALL BE ACCOMPLISHED BY THE USE OF A LASER INSTRUMENT UNLESS ANOTHER METHOD IS PREVIOUSLY APPROVED BY THE CITY.
7. THE CONTRACTOR SHALL AT ALL TIMES, DURING PIPE LAYING OPERATIONS, DEWATER THE GROUND SUFFICIENTLY TO KEEP THE GROUNDWATER ELEVATION A MINIMUM OF 6" BELOW THE PIPE BEING LAID WITHIN THE AREA OF THE TRENCH.
8. ALL PIPES SHALL BE LAID ON A FIRM FOUNDATION. SOFT OR SPONGY BEDDING FOR PIPES IS NOT ACCEPTABLE. ANY UNSUITABLE MATERIAL SHALL BE REMOVED AND REPLACED WITH A DRY, COMPACTED, GRANULAR MATERIAL SATISFACTORY TO THE CITY.
9. ON ALL EXCAVATION AND BACKFILLING THE CONTRACTOR SHALL PROVIDE ADEQUATE SHEETING AND BRACING IN ORDER TO PROVIDE FOR THE SAFETY OF WORKMEN, AS WELL AS REPRESENTATIVES OF THE CITY, THE DESIGN ENGINEER, AND THE DEVELOPER.
10. ALL TRENCHES SHALL BE BACKFILLED WITH ACCEPTABLE MATERIAL AND COMPACTED TO THE SPECIFIED MINIMUM COMPACTION (95% IN UNPAVED AREAS AND 98% IN PAVED AREAS) OF THE OPTIMUM DENSITY OF THAT MATERIAL BASED ON THE AASHTO T-180 MODIFIED PROCTOR TEST.
11. THE CONTRACTOR SHALL EMPLOY AN INDEPENDENT TESTING LABORATORY AT HIS OWN EXPENSE TO INSURE THAT COMPACTION OF ALL FILL MATERIAL IS COMPLETED PROPERLY. TESTS SHALL BE DONE ONE FOOT ABOVE THE PIPE AND THEN AT ONE FOOT VERTICAL INTERVALS UNTIL FINAL GRADE IS REACHED. TESTING SHALL BE COMPLETED AND TEST DOCUMENTS SUBMITTED TO THE CITY AT A MINIMUM FREQUENCY OF ONE SET OF TESTS BETWEEN EACH MANHOLE AND ONE ADDITIONAL SET OF TESTS AT EVERY MANHOLE. IDENTIFICATION OF TEST LOCATIONS SHALL BE CLEARLY INDICATED ON TEST REPORTS. TEST RESULTS SHALL BE FORWARDED PROMPTLY TO THE CITY'S DESIGNATED SITE INSPECTOR.
12. THE CONTRACTOR SHALL INSTALL A METALLIZED FOIL LOCATOR TAPE, OR SIMILAR DEVICE AS MAY BE APPROVED BY THE CITY FOR THE FULL LENGTH OF ALL PVC SEWAGE FORCE MAINS. THIS PIPE LOCATOR AID SHALL BE INSTALLED BETWEEN 15" AND 24" BELOW FINISHED GRADE OR AS DIRECTED BY THE MANUFACTURER. TAPE SHALL BE COLOR CODED GREEN FOR SANITARY SEWER AND FORCE MAIN. INSTALL 12 GAUGE TRACING WIRE IN TRENCH.



2024-07-20

STANDARD CONSTRUCTION DETAIL  
SANITARY SEWER DESIGN AND  
CONSTRUCTION NOTES

FILE NAME:

EW\_S23.DWG

DETAIL REF:

S-23

SANITARY SEWER DESIGN AND CONSTRUCTION NOTES:  
(CONTD.)

13. ALL TESTING REQUIRED BY THE CITY SHALL BE PAID FOR BY THE CONTRACTOR / DEVELOPER.
14. ALL LOCAL COLLECTION SANITARY SEWER MANHOLES SHALL BE PRECAST WITH A MINIMUM INSIDE DIAMETER OF 4 FEET.
15. STANDARD MANHOLES SHALL BE LOCATED AT INTERVALS NOT EXCEEDING 400 FEET.
16. ALL SEWER FITTINGS TO BE "HARCO" OR CITY APPROVED EQUAL.
17. MANHOLE RIMS SHALL MATCH FLUSH WITH THE FINISH GRADE ELEVATION IN PAVED AREAS AND A MINIMUM OF 0.2 FEET AND MAXIMUM OF 0.5 FEET ABOVE GRADE GENERALLY IN UNPAVED AREAS.
18. THE CONTRACTOR SHALL CONSTRUCT SANITARY SEWER MANHOLES IN SUCH A WAY THAT SEWER LINES DO NOT INTERSECT SEALED JOINTS BETWEEN SECTIONS OF THE MANHOLE.
19. RUBBER BOOTS AND STAINLESS STEEL BANDS SHALL BE UTILIZED IN THE CONNECTION OF THE SEWER MAIN TO THE MANHOLES (SEE STANDARD MANHOLE AND BOOT DETAIL).
20. INDIVIDUAL SANITARY SERVICE CONNECTORS ON NEW CONSTRUCTION SHALL NOT BE CONNECTED DIRECTLY INTO MANHOLES, AND MUST CONNECT TO SEWER MAIN LINES BY USE OF WYE CONNECTIONS, UNLESS OTHERWISE BE APPROVED BY THE CITY.
21. FOR SINGLE FAMILY HOMES, SINGLE OR DOUBLE FOUR INCH SEWER SERVICES LATERALS SHALL BE CONSTRUCTED SINGLES AT EACH LOT OR UNIT AND LOCATED ON THE DOWNSTREAM SIDE OF THE LOT CENTER LINE. DOUBLES LOCATED ON THE LOT LINES THESE SERVICES SHALL BE EXTENDED 4 FEET ABOVE GROUND AT THE PROPERTY LINE WITH A PVC RISER AND PLUG BEING EASILY VISIBLE FROM THE ROAD. RUBBER SEAL FITTINGS SHALL BE USED ON ALL LINES. NO GLUED JOINTS ARE PERMITTED ON LATERALS, INCLUDING DOUBLES.
22. FOR MULTI-FAMILY AND COMMERCIAL SITES, SIX INCH MINIMUM SEWER SERVICES AND CLEANOUTS SHALL BE PROVIDED AS APPROVED BY THE CITY.
23. SANITARY SEWER LIFT STATIONS AND FORCE MAINS, SIZE, MATERIAL, AND DESIGNS SHALL BE APPROVED BY THE CITY. LIFT STATIONS SHALL BE CONSTRUCTED WITH A MINIMUM WET WELL INTERIOR DIAMETER OF 6 FEET. FORCE MAINS SHALL BE A MINIMUM 6 INCH DIAMETER.
24. IT SHALL BE THE RESPONSIBILITY OF THE DESIGN ENGINEER TO PREPARE AND SUBMIT FLOTATION CALCULATIONS TO SIZE THE BASE OF THE WET WELL, AND ANY MANHOLES AS DEEMED NECESSARY BY THE CITY.
25. SANITARY SEWER DROP MANHOLES SHALL ONLY BE USED UNDER SPECIAL CONDITIONS AS APPROVED BY THE CITY. DROPS LESS THAN 2.0' SHALL NOT BE ALLOWED.
26. ALL SANITARY SEWER MANHOLE COVERS SHALL HAVE THE WORDS "EDGEWATER, FLORIDA SANITARY SEWER" CAST INTO THEM.
27. ALL SANITARY SEWER FORCE MAINS, SHALL BE PVC AWWA C-900, OR C-905 (COLOR "GREEN") (PRESSURE FITTINGS, PRESSURE CLASS 150 OR 250 EPOXY LINED DIP. THE FORCE MAIN MINIMUM DEPTH OF COVER SHALL BE 36".
28. ALL SANITARY SEWER FORCE MAINS SHALL USE A THRUST RESTRAINT JOINT METHOD IN COMPLIANCE WITH THE DUCTILE IRON PIPE RESEARCH ASSOCIATION GUIDELINES MODIFIED TO ACCOMMODATE PVC PIPE BY FOLLOWING THE RECOMMENDED INCREASE IN RESTRAINT LENGTH CORRESPONDING TO THE INSTALLATION OF POLYETHYLENE WRAP. IN NO INSTANCE SHALL THRUST BLOCKS BE PERMITTED.



STANDARD CONSTRUCTION DETAIL  
SANITARY SEWER DESIGN AND  
CONSTRUCTION NOTES

FILE NAME:

EW\_S24.DWG

DETAIL REF:

S-24

SANITARY SEWER DESIGN AND CONSTRUCTION NOTES  
(CONTD.)

29. SANITARY SEWER MANHOLES WHICH HAVE SEWER FORCE MAINS DISCHARGING DIRECTLY INTO THEM SHALL BE FIBERGLASS OR POLY-ETHYLENE LINED. RETRO-FITTING OF MANHOLES WITH LINERS SHALL BE REQUIRED WHEN NEW CONNECTIONS SUCH AS THIS ARE MADE. FIBERGLASS SHALL BE A MINIMUM 1/2" THICKNESS UNLESS APPROVED OTHERWISE BY THE CITY. OTHER TYPES OF LINING METHODS AND MATERIALS MAY BE CONSIDERED ON A CASE BY CASE BASIS.
  
30. THE CITY RESERVES THE RIGHT TO REQUIRE THE DEVELOPER TO PERFORM VACUUM TESTING OF ALL SANITARY MANHOLES, AIR TEST SEWER MAINS, AND REQUIRES THAT ALL SANITARY SEWER MAIN LINES BE TELEVISED PRIOR TO FINAL ACCEPTANCE. LATERALS SHALL BE TELEVISED UPON DEMAND BY THE CITY PRIOR TO FINAL ACCEPTANCE WHEN IT IS SUSPECTED THAT A PROBLEM EXISTS.
  
31. ALL SEWER MAINS, PRIOR TO ACCEPTANCE BY THE CITY AND PRIOR TO ANY FINAL PAVING OPERATIONS, SHALL BE CLEANED FLUSHED AND TELEVISED USING A "PAN AND TILT" CAMERA BY A CITY APPROVED CONTRACTOR. THE VIDEO SHALL BE NON-STOP WITH AUDIO DESCRIBING WHAT IS BEING REVIEWED. WRITTEN VIDEO LOGS DESCRIBING THE CONDITION OF THE LINES SHALL ACCOMPANY THE TAPE SUBMISSION TO THE CITY PRIOR TO COMMENCING ANY INSTALLATION OF ASPHALT OR CONCRETE PAVEMENT. RE-TAPING MAY BE REQUIRED BY THE CITY IF ADDITIONAL CLEARING OR CORRECTIVE ACTIONS ARE NECESSARY.
  
32. ALL MANHOLES WITH FORCE MAIN CONNECTIONS SHALL BE OUTFITTED WITH EGRU LINERS OR OTHER TYPES OF LINERS APPROVED BY THE CITY. IN ADDITION, THE CITY MAY REQUIRE LINERS TO BE INSTALLED IN AREAS WHERE THE ENVIRONMENTAL SERVICES DEPARTMENT BELIEVES THE NEED IS JUSTIFIED.
  
33. ALL SEWER LINES WHICH ARE CONSTRUCTED OUTSIDE OF PUBLIC RIGHTS-OF-WAY WITHIN SIDE YARDS, BACKYARDS, AND OTHER POORLY ACCESSIBLE AREAS SHALL BE CONSTRUCTED OF C-900 PVC. ABSOLUTELY NO USE OF PLASTIC STYRENE FITTINGS SHALL BE ALLOWED.
  
34. SEWER LATERAL LOCATIONS SHALL BE MARKED ALONG THE OUTSIDE OF THE CURB WITH A SAW CUT "V", OR BY A METAL TAB SET INTO THE PAVEMENT.
  
35. CONTEC A-2000 PVC PIPE SHALL NOT BE ALLOWED FOR USE.
  
36. EZ-WRAP PLASTIC, AS MANUFACTURED BY PRESS SEAL GASKET CORPORATION, SHALL BE USED ON THE OUTSIDE OF ALL MANHOLE AND WETWELL JOINTS. APPLY ONE LAYER OF 9" WRAP CENTERED ON EACH JOINT. A CITY INSPECTOR SHALL PERSONALLY INSPECT ALL JOINT SEALS PRIOR TO BACKFILLING OPERATIONS.
  
37. ALL PROPOSED SEWER FORCE MAINS SHALL BE FLUSHED, PRESSURE TESTED AND CLEARED FOR SERVICE IN ACCORDANCE WITH THE LATEST AWWA STANDARDS AND THE FLORIDA DEPARTMENT OF ENVIROMENTAL PROTECTION REQUIREMENTS. THE CONTRACTOR SHALL NOTIFY THE CITY'S DESIGNATED SITE INSPECTOR WHO SHALL COORDINATE WITH CITY PERSONNEL AT THE ENVIRONMENTAL SERVICES DEPARTMENT (AS APPROPRIATE) AT LEAST 24 HOURS PRIOR TO BEGINNING A FULL-DIAMETER FLUSH OF THE MAINS PRIOR TO THE COMMENCEMENT OF PRESSURE TESTING (SUBJECT TO AVAILABILITY).
  
38. THE CITY MAY REQUIRE THE CONTRACTOR TO PIG FORCE MAINS 6" AND GREATER IN DIAMETER AND PRIMARY TRANSMISSION MAINS LOCATED ON COLLECTOR AND ARTERIAL ROADWAYS. LAUNCHING AND EXTRACTION POINTS SHALL BE DETERMINED BY THE CONTRACTOR.



2024-07-20

STANDARD CONSTRUCTION DETAIL  
SANITARY SEWER DESIGN AND  
CONSTRUCTION NOTES

FILE NAME:

EW\_S25.DWG

DETAIL REF:

S-25

SANITARY SEWER DESIGN AND CONSTRUCTION NOTES  
(CONTD.)

39. ANY TIE INTO AN EXISTING MANHOLE WILL BE COORDINATED WITH THE CITY, AND ALL CONFINED SPACE HAZARDS AND PROCEDURES WILL BE FOLLOWED.
40. ANY TIE INTO AN EXISTING SYSTEM WILL BE SWEEPED IN THE DIRECTION OF FLOW.
41. THE CONTRACTOR WILL BE RESPONSIBLE FOR ALL OSHA, DOT, OR ANY OTHER RULES & REGULATIONS THAT MAY APPLY.
42. AS A GENERAL RULE, THE NUMBER OF JOINTS SHALL BE LIMITED WHENEVER POSSIBLE. IN SPECIAL CASES WHERE A POINT REPAIR TO AN 8" TO 12" PVC SEWER MAIN IS REQUIRED, THE PROPER RIGID WRAP AROUND SLEEVE SUCH AS A JCM-210 OVERSIZED DUCTILE IRON COUPLING OR AN APPROVED EQUAL MAY BE ALLOWED BY SPECIAL APPROVAL BY THE CITY.
43. ALL IN-LINE SANITARY SEWER FORCE MAIN VALVES SHALL BE RESILIENT SEAT (AWWA C-509) VALVES FEATURING A LINED DUCTILE IRON BODY.
44. ALL TAPPING OF MAINS AND CORING OF MANHOLES SHALL BE COORDINATED WITH THE CITY BY AN APPROVED CONTRACTOR AND BILLED IN ACCORDANCE WITH THE ADOPTED FEE RESOLUTION. SCHEDULING OF THESE CONNECTIONS SHALL REQUIRE A MINIMUM 48 HOUR NOTIFICATION (MEASURED ON NORMAL WORK DAYS) DIRECTED TO THE CITY'S DESIGNATED SITE INSPECTOR WHO SHALL COORDINATE THE WORK DIRECTLY WITH THE ENVIRONMENTAL SERVICE DEPARTMENT. SUBSEQUENTLY, THE CONNECTION SHALL BE SCHEDULED TO COMMENCE ON THE APPROPRIATE DAY AND TIME ESTABLISHED BY CITY.
45. WITH RESPECT TO TIE-IN CONNECTIONS AND CORING OPERATIONS, THE CITY RESERVES THE RIGHT TO REQUIRE CONNECTIONS TO BE PERFORMED DURING PERIODS OF LOW FLOW (MIDNIGHT TO 6:00 A.M.) IN ORDER TO MINIMIZE SERVICE DISRUPTION TO EXISTING CUSTOMERS.
46. ALL WORK PERFORMED UPON SANITARY SEWER FACILITIES OWNED OR PROPOSED TO BE OWNED BY THE CITY SHALL BE CONSTRUCTED BY A LICENSED UNDERGROUND UTILITY CONTRACTOR, OR LICENSED GENERAL CONTRACTOR, WHO IS LICENSED IN THE STATE OF FLORIDA AND REGISTERED WITH THE CITY.
47. UPON CONSTRUCTION COMPLETION AND ACCEPTANCE OF THE SYSTEM, IT SHALL BE THE DESIGN ENGINEER'S RESPONSIBILITY TO ENSURE THAT THE SYSTEM IS PROPERLY CERTIFIED AND ACCEPTED BY THE FLORIDA DEPARTMENT OF ENVIRONMENTAL PROTECTION AND AS-BUILTS ARE PROVIDED TO THE CITY PRIOR TO ANY USE OF THE SYSTEM.
48. FOR CONSTRUCTION PURPOSES, THE PLANS SHALL DIMENSION THE LOCATION, OF ALL FORCE MAINS MEASURED FROM THE BACK OF CURB ( OR EDGE OF PAVEMENT, IF NO CURBING EXISTS. )
49. ALL HDPE PIPE INSTALLED FOR SEWAGE FORCE MAINS SHALL BE SDR 11 UNLESS SPECIFICALLY NOTED OTHERWISE. THE HDPE PIPE SHALL BE SIZED TO MATCH THE EXTERNAL DIAMETER OF THE PVC OR DIP TO WHICH IT IS ATTACHED.
50. LANDSCAPE PLANS SHALL CLEARLY DEPICT THE DESIGN LOCATION OF PLANTINGS RELATIVE TO THE LOCATION OF PUBLIC UTILITIES AND STORMWATER INFRASTRUCTURE IN ORDER TO EVALUATE POTENTIAL CONFLICTS.
51. ALL UTILITY INSTALLATIONS ARE SUBJECT TO REVIEW AND APPEAL BY THE CITY OF EDGEWATER. ALL STRUCTURES AND EQUIPMENT SUPPLIED AND/ OR INSTALLED SHALL MEET QUALITY AND PERFORMANCE STANDARDS PRIOR TO ACCEPTANCE. SUBSTANDARD INSTALLATIONS MAY BE REJECTED, REMEMBER MEASURES ARE SUBJECT TO CITY APPROVAL.



2023-01-25

STANDARD CONSTRUCTION DETAIL  
SANITARY SEWER DESIGN AND  
CONSTRUCTION NOTES

FILE NAME:

EW\_S26.DWG

DETAIL REF:

S-26



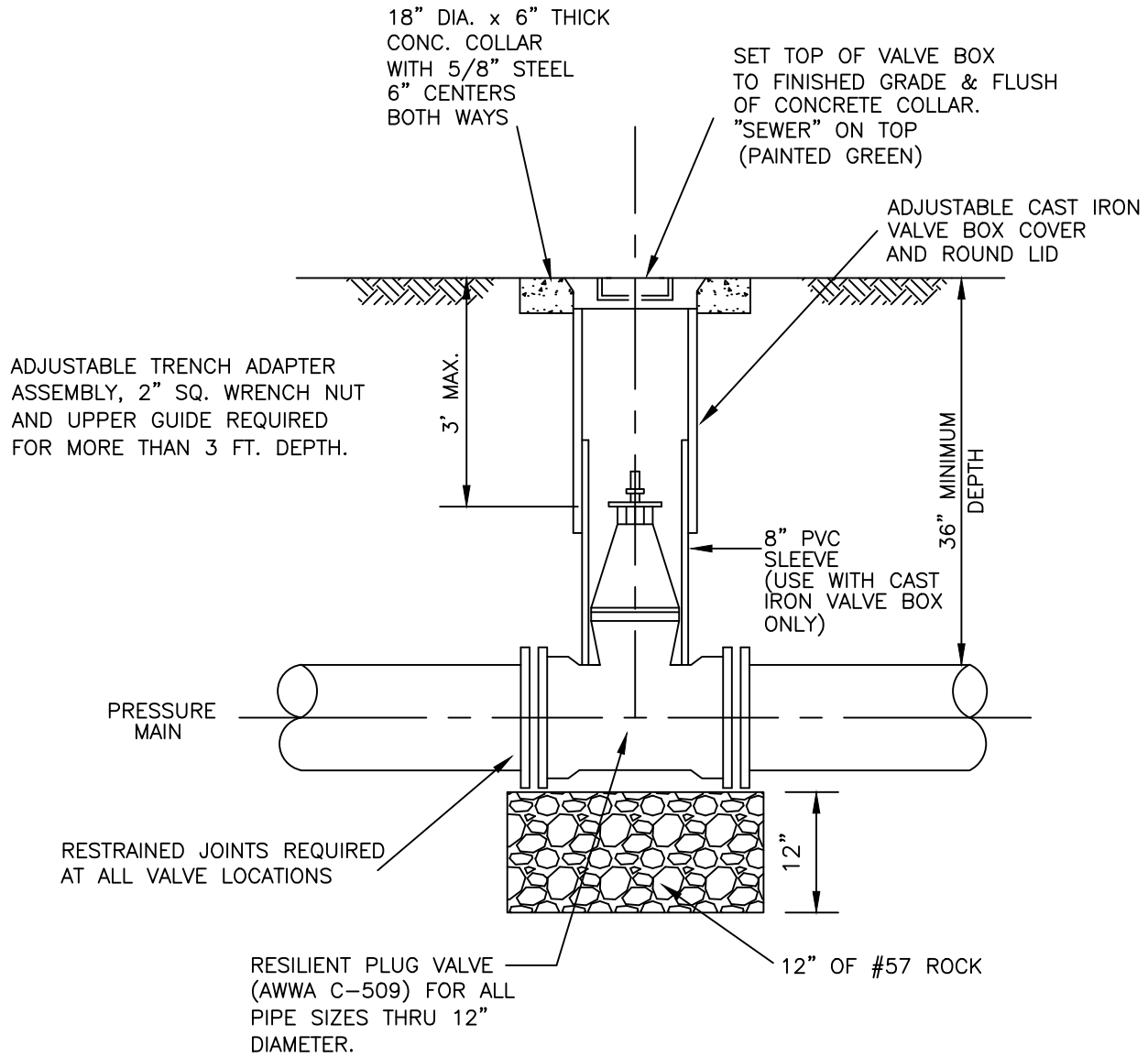

**NOTE:**

1. ROD OR BOLT TO TEE WHERE APPLICABLE.



2023-01-25

STANDARD CONSTRUCTION DETAIL  
SANITARY SEWER FORCE MAIN VALVE & VALVE BOX

FILE NAME:

EW\_S27.DWG

DETAIL REF:

S-27

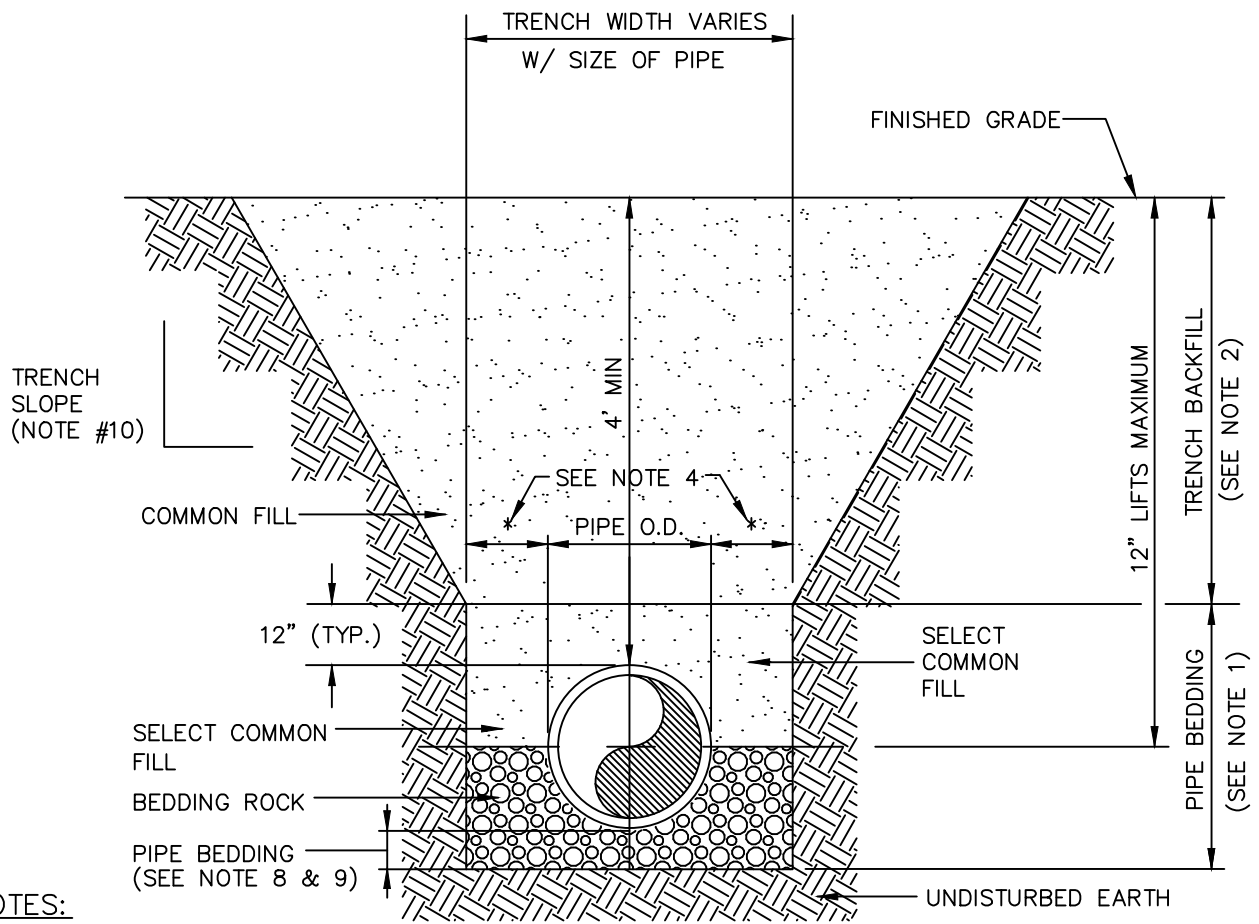

**NOTES:**

1. PIPE BEDDING: SELECT COMMON FILL COMPACTED TO 95% OF THE MAXIMUM DENSITY AS PER AASHTO T-180.
2. TRENCH BACKFILL: COMMON FILL COMPACTED TO 95% OF THE MAXIMUM DENSITY AS PER AASHTO T-180. (98% DENSITY REQUIRED UNDER PAVEMENT, DRIVEWAYS AND STRUCTURES.)
3. USE TYPE "A" BEDDING TO BE DETERMINED IN THE FIELD AS DIRECTED BY THE CITY.
4. (\*): 15" MAX. FOR PIPE DIAMETER LESS THAN 24", AND 24" MAX. FOR PIPE DIAMETER 24" AND LARGER.
5. WATER SHALL NOT BE PERMITTED IN THE TRENCH DURING CONSTRUCTION.
6. ALL PIPE TO BE INSTALLED WITH BELL FACING UPSTREAM TO THE DIRECTION OF FLOW.
7. REFER TO SECTION 32.5 OF THE MANUAL FOR SHEETING AND BRACING IN EXCAVATIONS.
8. GRAVITY SEWERS SHALL UTILIZE TYPE "A" BEDDING, WHERE UNSUITABLE MATERIAL EXISTS. BEDDING DEPTH SHALL BE 4" MINIMUM FOR PIPE DIAMETER LESS THAN 15", AND 6" MINIMUM FOR PIPE DIAMETER 16" AND LARGER.
9. DEPTH FOR REMOVAL OF UNSUITABLE MATERIAL SHALL GOVERN DEPTH OF BEDDING ROCK BELOW THE PIPE. CITY SHALL DETERMINE IN THE FIELD REQUIRED REMOVAL OF UNSUITABLE MATERIAL TO REACH SUITABLE FOUNDATION.
10. REFER TO OSHA REQMTS. FOR SLOPING, SHEETING AND BRACING IN EXCAVATIONS.

|   |  |                                  |
|---|--|----------------------------------|
|  <p>2023-01-25</p> | <p>STANDARD CONSTRUCTION DETAIL<br/>TYPE "A" BEDDING AND TRENCH DETAIL<br/>(SPECIAL GRAVITY SEWER INSTALLATIONS)</p> | <p>FILE NAME:<br/>EW_S28.DWG</p> |
|   |  | <p>DETAIL REF:<br/>S-28</p>      |
|   |  |                                  |



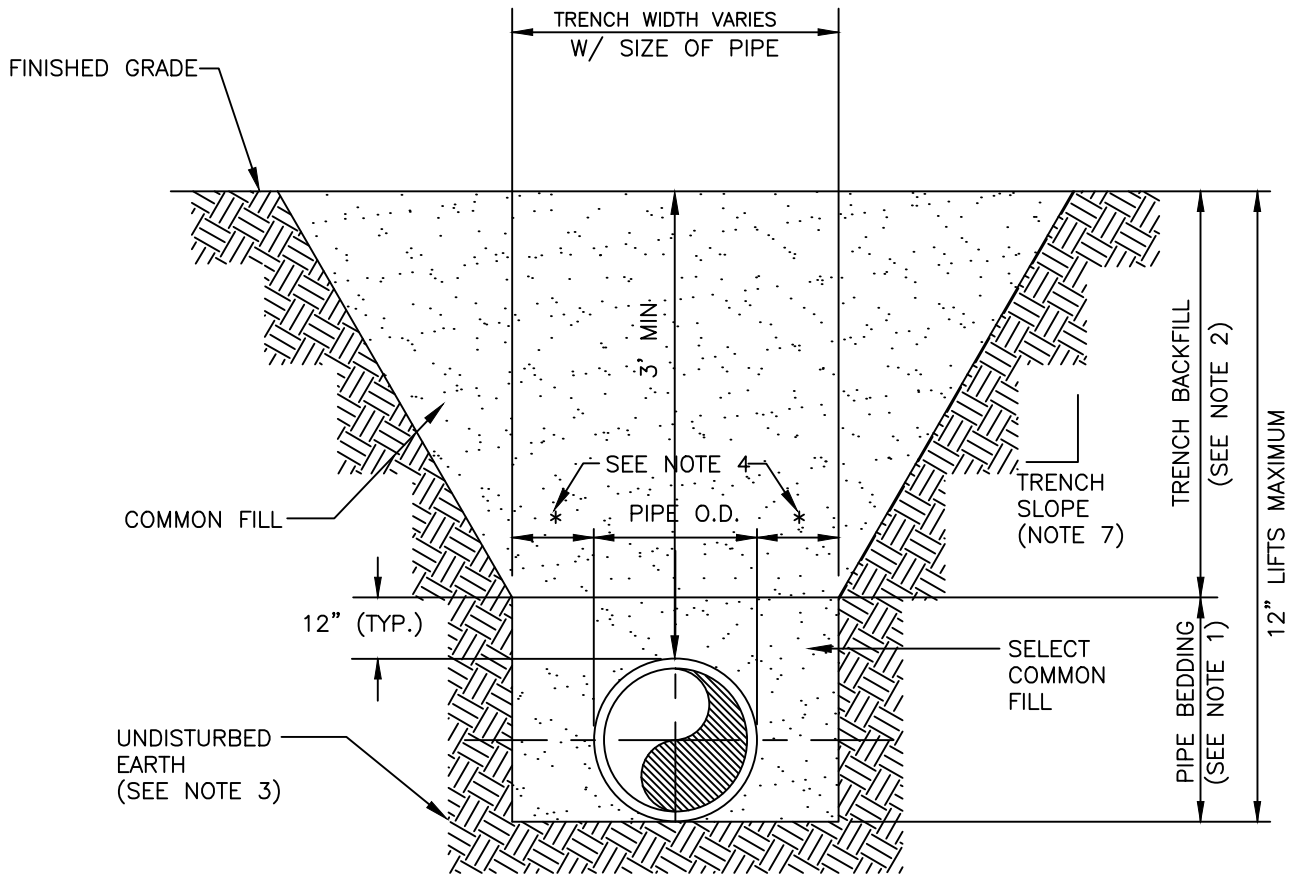

**NOTES:**

1. PIPE BEDDING: SELECT COMMON FILL COMPACTED TO 95% OF THE MAXIMUM DENSITY AS PER AASHTO T-180.
2. TRENCH BACKFILL: COMMON FILL COMPACTED TO 95% OF THE MAXIMUM DENSITY AS PER AASHTO T-180, (98% DENSITY REQUIRED UNDER DRIVEWAYS, PAVEMENT AND STRUCTURES).
3. PIPE BEDDING UTILIZING SELECT COMMON FILL OR BEDDING ROCK IN ACCORDANCE WITH TYPE "A" BEDDING AND TRENCHING DETAIL MAY BE REQUIRED AS DIRECTED BY THE CITY.
4. (\*): 15" MAX. FOR PIPE DIAMETER LESS THAN 24", AND 24" MAX. FOR PIPE DIAMETER 24" AND LARGER.
5. WATER SHALL NOT BE PERMITTED IN THE TRENCH DURING CONSTRUCTION.
6. ALL PIPE TO BE INSTALLED WITH BELL FACING UPSTREAM TO THE DIRECTION OF FLOW.
7. REFER TO OSHA REQUIREMENTS FOR SLOPING, SHEETING AND BRACING IN EXCAVATIONS.
8. FINAL RESTORATION IN IMPROVED AREAS SHALL BE IN COMPLIANCE WITH ALL APPLICABLE REGULATIONS OF GOVERNING AGENCIES. SURFACE RESTORATION WITHIN RIGHT-OF-WAY SHALL COMPLY WITH REQUIREMENTS OF RIGHT-OF-WAY UTILIZATION REGULATIONS AND ROAD CONSTRUCTION SPECIFICATIONS.



2023-01-25

STANDARD CONSTRUCTION DETAIL  
 TYPE "B" BEDDING AND TRENCH DETAIL  
 (TYPICAL FOR WATER, SEWER, FORCE MAIN, STORM  
 DRAIN AND RECLAIMED WATER MAIN INSTALLATIONS)

FILE NAME:

EW\_S29.DWG

DETAIL REF:

S-29

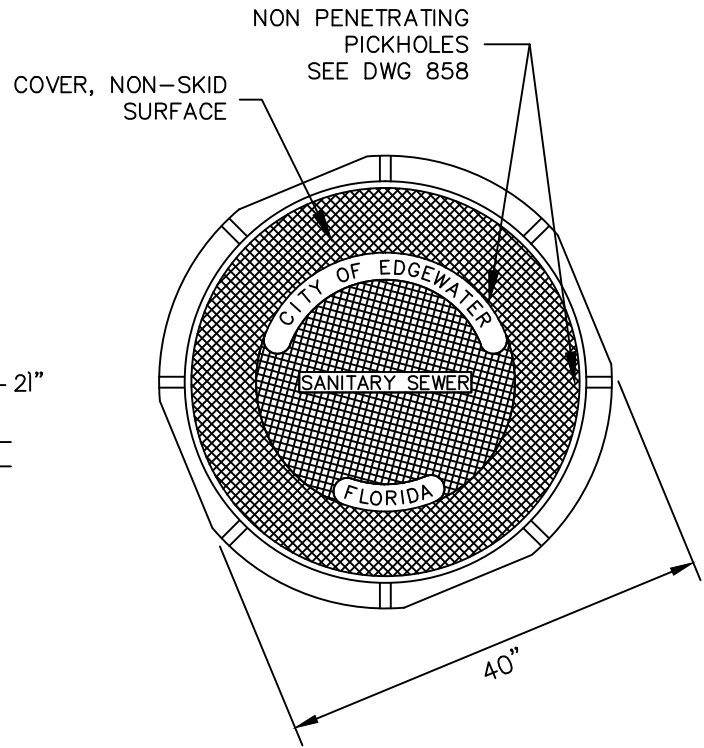
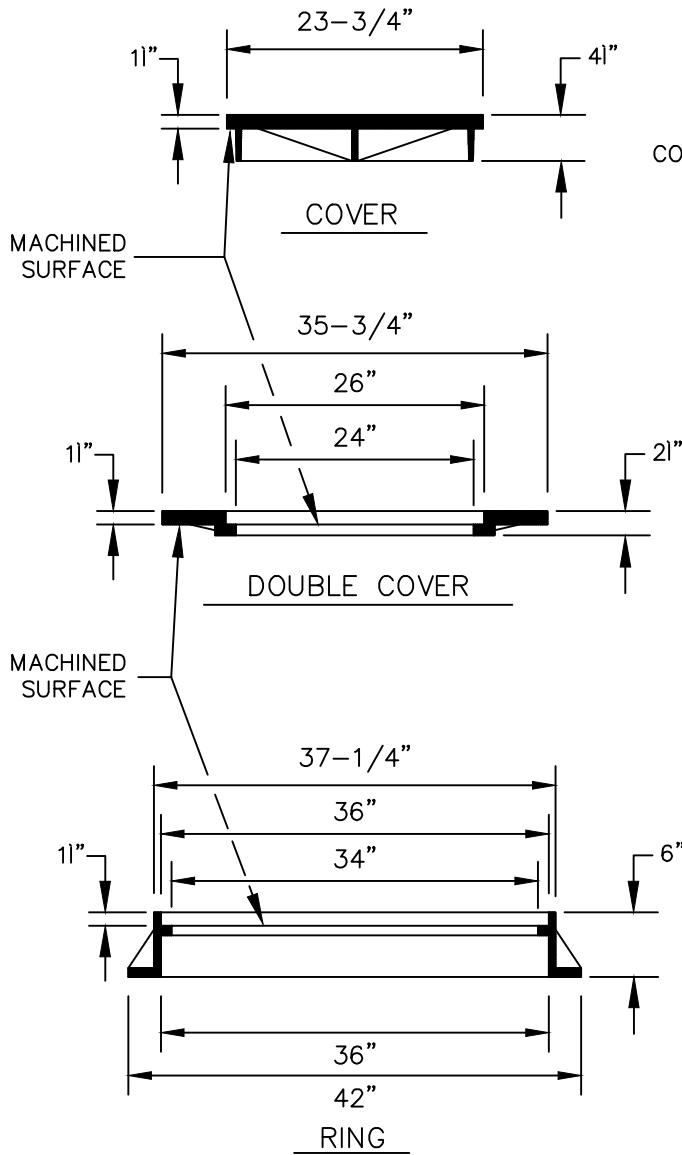

**NOTES:**

1. U.S. FOUNDRY 666 RING & CR-ORS & XB-ORS COVERS
2. COVER WT.: 212 LBS. APP. (185 LBS. ACTUAL)
3. DOUBLE COVER WT.: 215 LBS. APP.
4. RING WT.: 225 LBS. APP.
5. MATERIAL: ASTM-A48 CLASS 30B GRAY IRON



2023-01-25

STANDARD CONSTRUCTION DETAIL  
SANITARY SEWER DOUBLE MANHOLE COVER

FILE NAME:

EW\_S30.DWG

DETAIL REF:

S-30

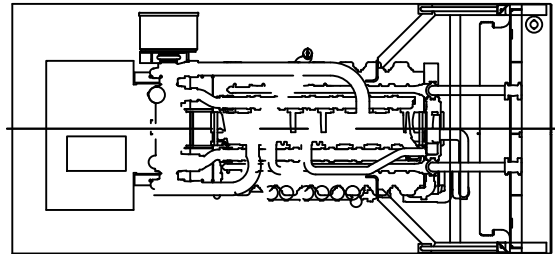
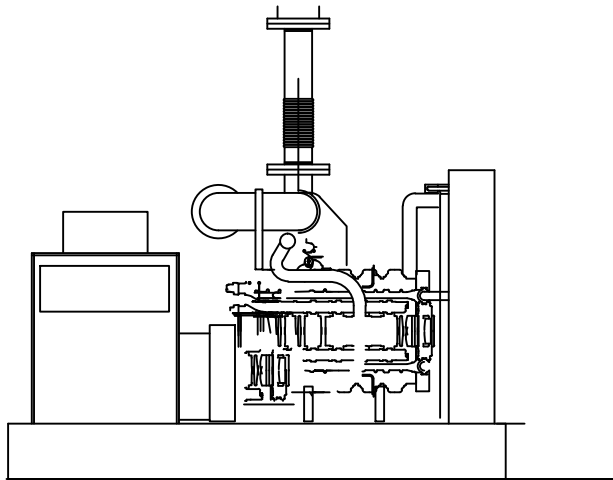

NOTES:

1. ANY LIFT STATION WILL BE SUPPORTED BY A PERMANENTLY INSTALLED DIESEL DRIVEN BYPASS PUMP AS MANUFACTURED BY ATLAS COPCO, UNLESS IF DETERMINED INFEASIBLE BY THE CITY ENGINEER IN WHICH CASE A PERMANENTLY INSTALLED STANDBY GENERATOR SHALL BE PROVIDED.
2. GENERATOR SHALL BE MANUFACTURED BY OLYMPIAN OR OTHER CITY APPROVED EQUAL.
3. AN AUTOMATIC TRANSFER SWITCH WILL BE INSTALLED BETWEEN THE GENERATOR AND THE ELECTRIC PANEL.
4. THE GENERATOR SHALL BE RATED AT THE MAXIMUM STATION AMPERAGE PLUS 25 PERCENT.
5. THE GENERATOR SHALL BE MOUNTED ON A 28 DAY, 3,000 p.s.i., SIX INCH (6") THICK, SLAB WITH A MINIMUM TWO FOOT (2') SKIRT ON ALL FOUR SIDES.
6. THE GENERATOR SHALL HAVE ON SITE FUEL STORAGE SUFFICIENT TO RUN THE GENERATOR FOR A MINIMUM OF 24 HOURS.
7. THE GENERATOR SHALL BE ENCLOSED BY A NEMA RATED WATERPROOF ENCLOSURE AND BE SOUND ATTENUATED.
8. CONTRACTOR SHALL BE RESPONSIBLE FOR A MANUFACTURER'S START UP WITH THE CITY IN ATTENDANCE.



2024-07-20

STANDARD CONSTRUCTION DETAIL  
EMERGENCY BACKUP PUMP OR GENERATOR

FILE NAME:

EW\_S31.DWG

DETAIL REF:

S-31